

17424/\*\*/PN



Gebruiksaanwijzing  
Notice d'emploi  
Benutzerhandbuch  
User manual  
Manual de usuario



**PHILIPS**

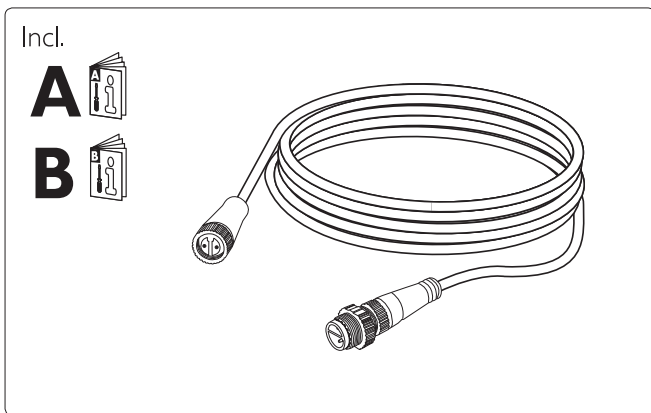

[www.meethue.com/getstarted](http://www.meethue.com/getstarted)



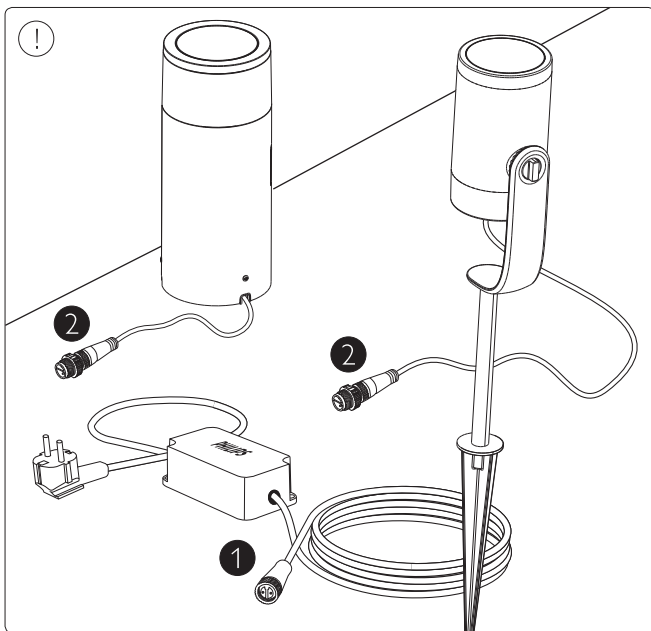
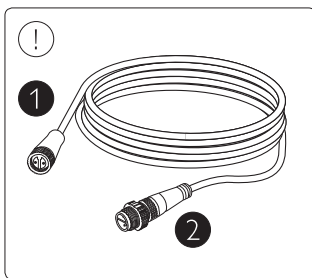
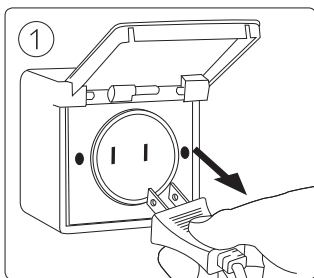

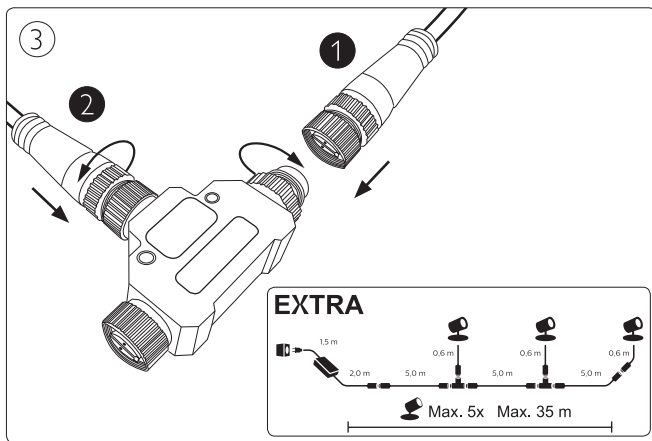
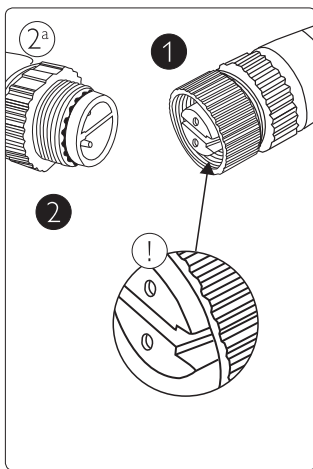
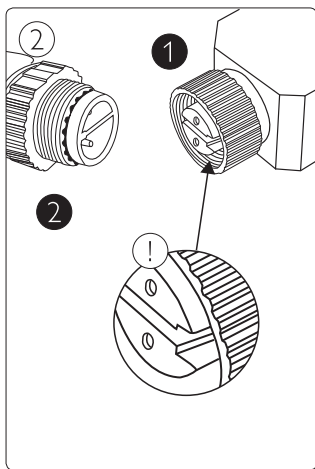

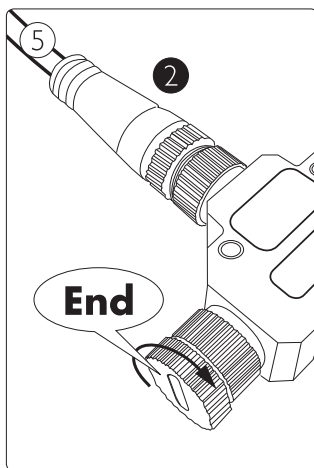
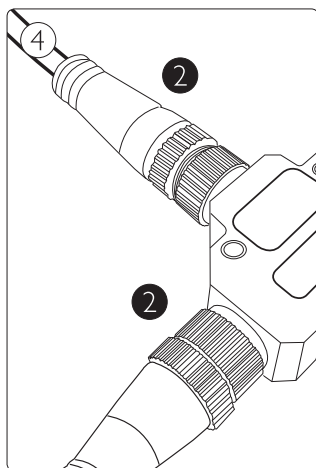

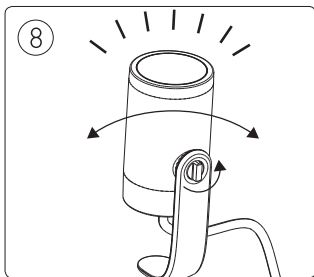
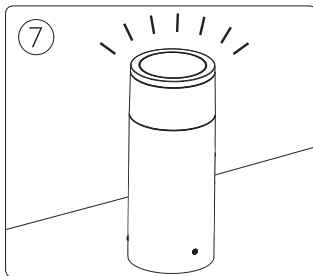
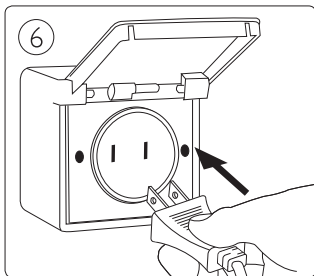



- EN** Use only with Philips Hue 24V luminaires!
- DE** Verwenden Sie nur mit Philips Hue 24V Leuchten!
- FR** Utiliser uniquement avec les luminaires Philips Hue 24V!
- ES** Utilizar solamente con Philips Hue 24V luminarias!
- PT** Utilize apenas com luminárias Philips Hue 24V!
- IT** Utilizzare solo con apparecchi Philips Hue 24V!



Philips Lighting Contact Centre  
Int. Business Reply Service  
I,B,R,S. / C,C,R,I. Numéro 10461  
5600 VB Eindhoven  
Pays-Bas / The Netherlands

[www.meethue.com/getstarted](http://www.meethue.com/getstarted)  
[www.philips.com](http://www.philips.com)  
☎ +800 7445 4775

440402909931  
Last update: 07/02/18