

19650-4

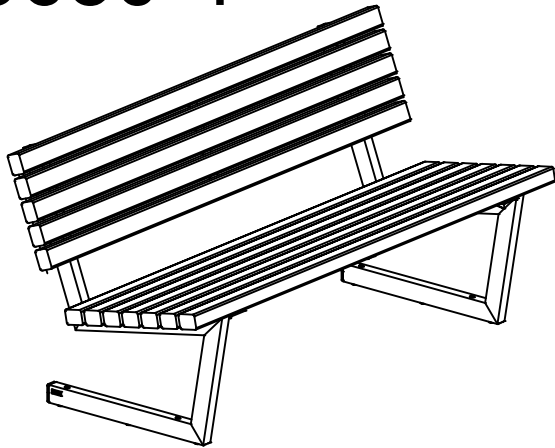

150 cm

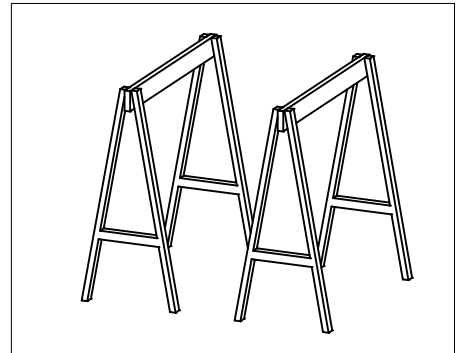
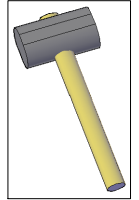
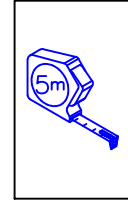
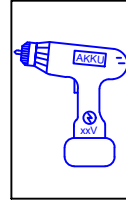

19652-4

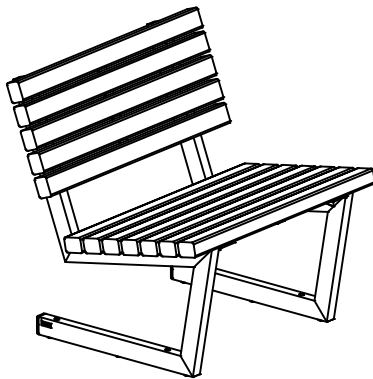

75 cm

DK: Vi anbefaler at være to personer til samling/montering af produktet.
Se www.plus.dk for yderligere information og vedligehold af materialer.

SE: Vi rekommenderar att man är två personer för montering/installation av produkten.
Se www.plus.dk för ytterligare information och underhåll av material.

DE: Wir empfehlen, dass die Montage des Produktes von zwei Personen durchgeführt wird.
Weitere Informationen und Pflegehinweise finden Sie unter www.plus.dk.

UK: We recommend two people for assembly/mounting of the product.
www.plus.dk for further information and maintenance of materials.

FR: Nous vous recommandons d'être à deux pour procéder à l'assemblage/au montage du produit.
Voir www.plus.dk pour plus d'informations et d'entretien de matériel.



PLUS

PLUS A/S
Ådalen 13B
DK-6600 Vejen
phone: +45 7996 3333
web: www.plus.dk

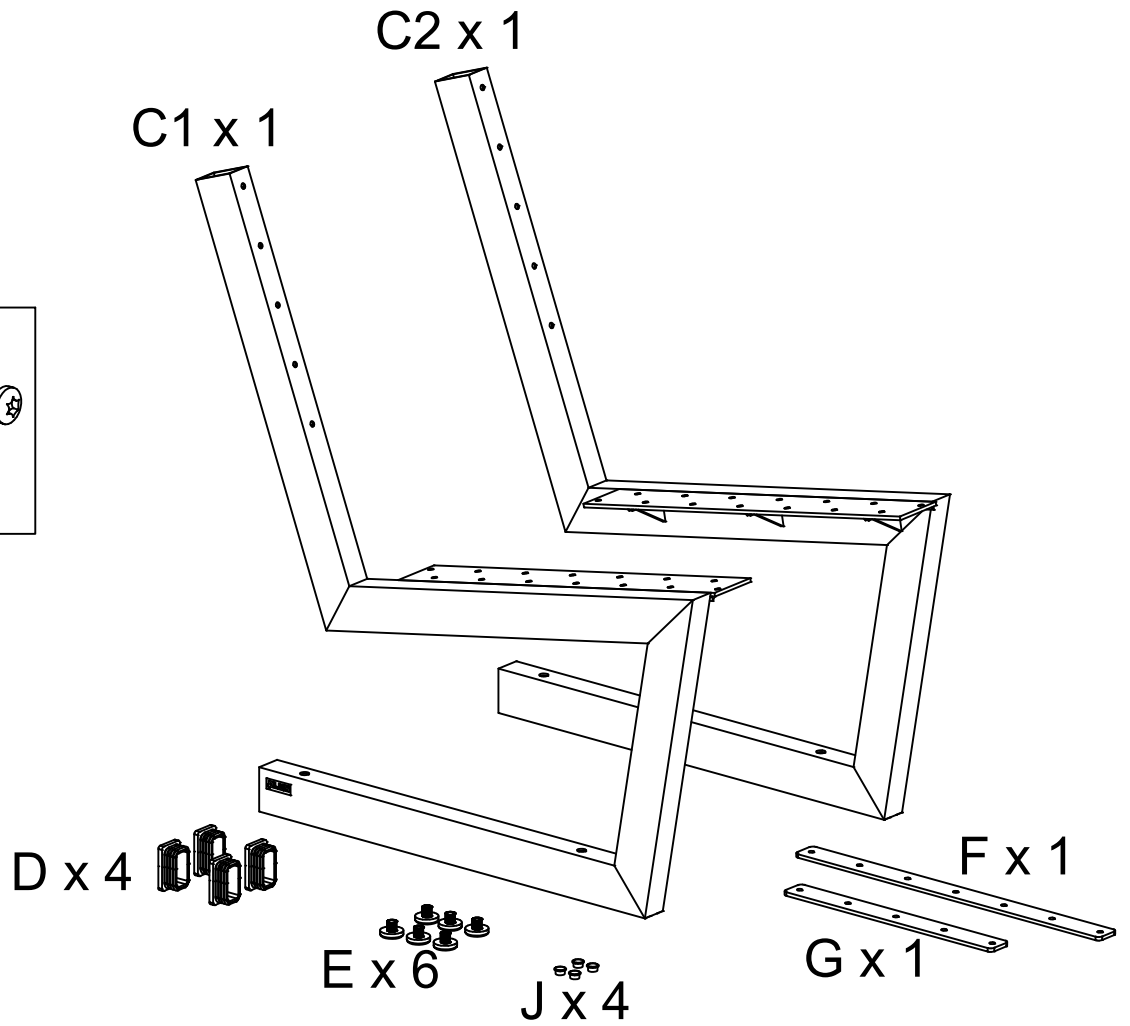
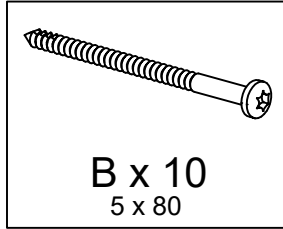
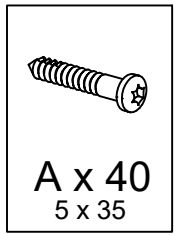

19652-4

19650-4

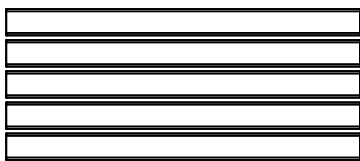

5 x H = 42x56x750 mm
(18572-4)



5 x l = 42x56x1500 mm
(18571-4)

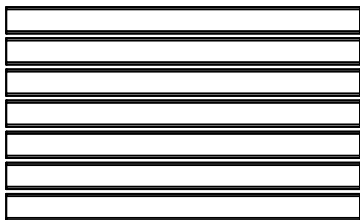

7 x H = 42x56x750 mm
(18572-4)

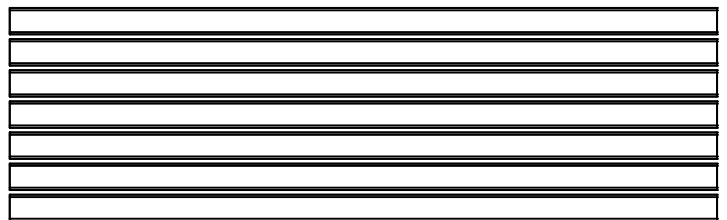

7 x l = 42x56x1500 mm
(18571-4)

19652-4

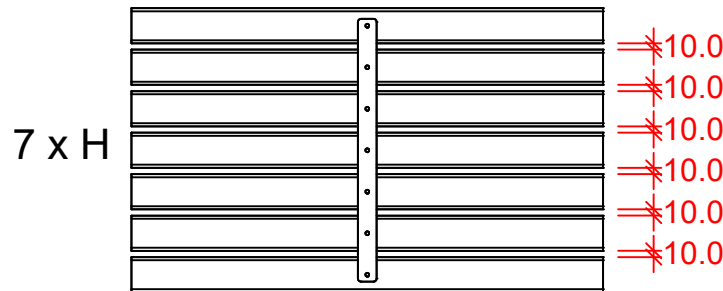
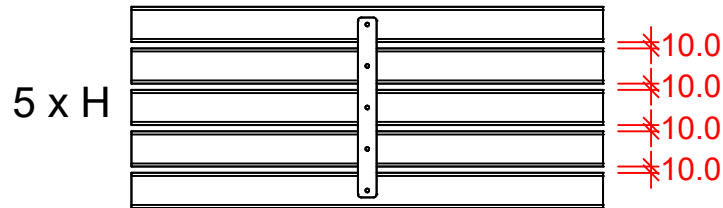
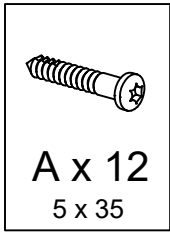

19650-4

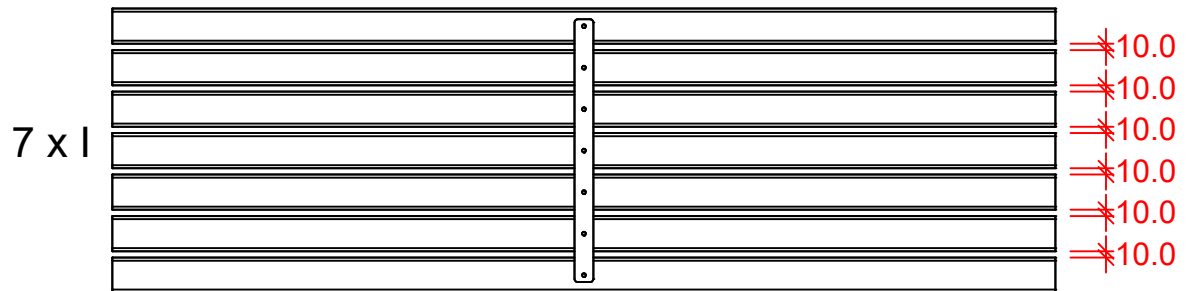
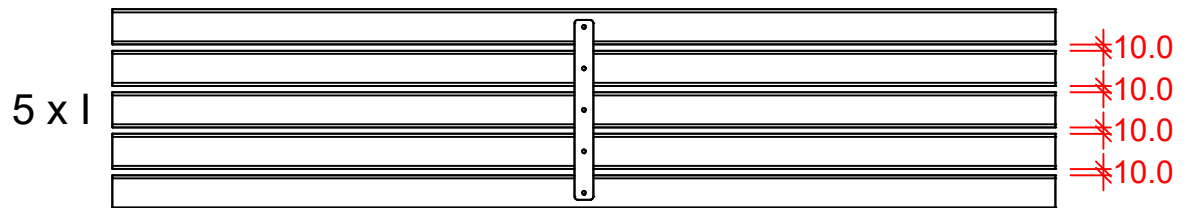
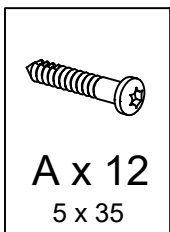

Viktigt - Important - Wichtig - Viktig..!

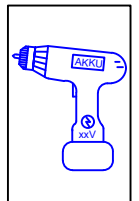

DK: Fastskrues stille og roligt.

Da ThermoWood er meget sprødt og nemt kan flække, hvis der skrues for hurtigt.

SE: Skruvas fast lugt och stadigt.

Eftersom ThermoWood är mycket sprött och lätt kan spricka om det skruvas för snabbt.

DE: Ruhig und gleichmäßig angeschraubt.

Denn ThermoWood ist sehr spröde und kann bei zu schnellem Verschrauben leicht reißen.

UK: Screwed on quietly and steadily.

Because ThermoWood is very brittle and can easily crack if screwed too fast.

FR: Vissé tranquillement et régulièrement.

Parce que le ThermoWood est très fragile et peut facilement se fissurer s'il est vissé trop rapidement.

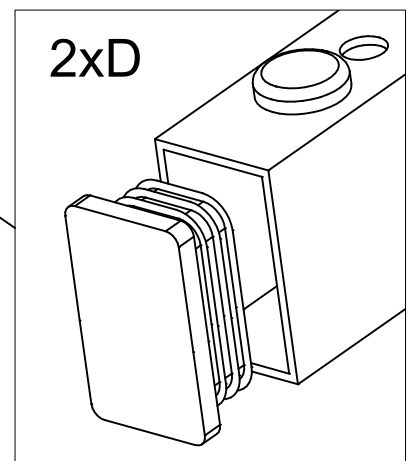
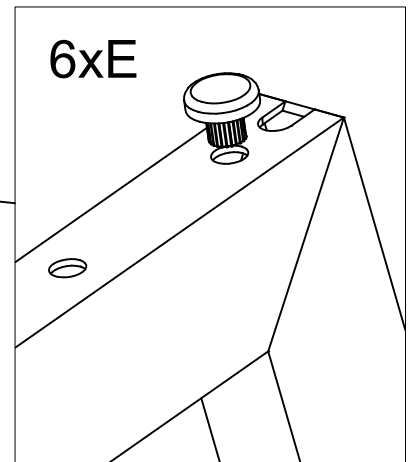
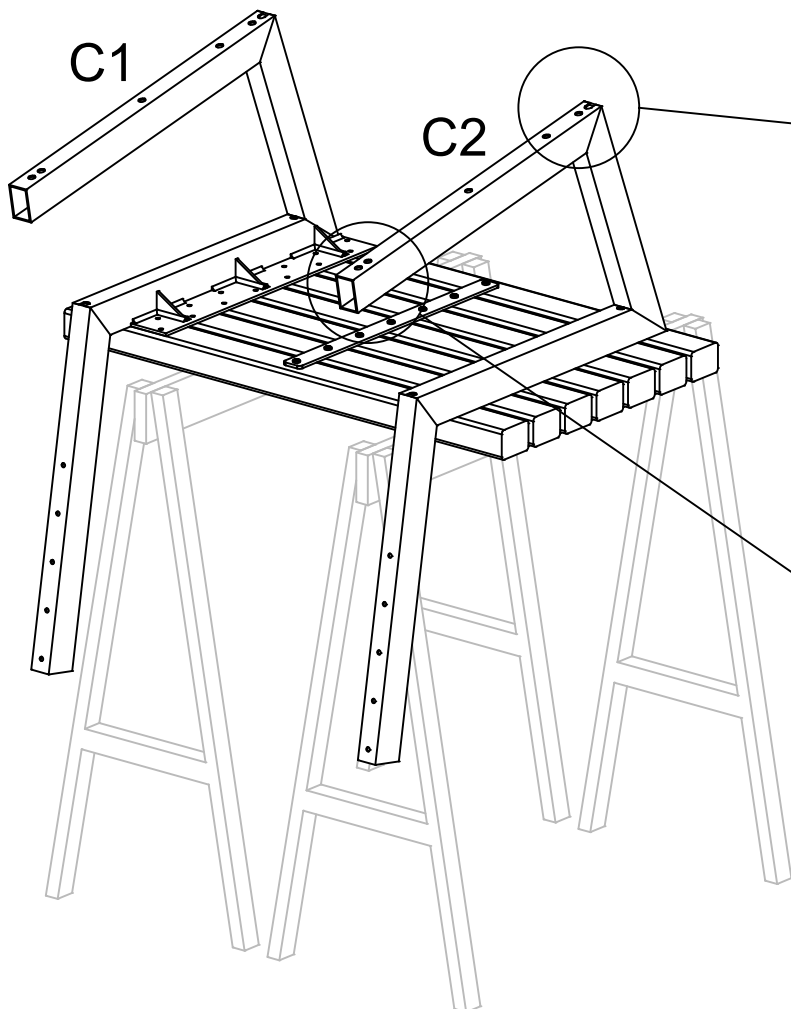
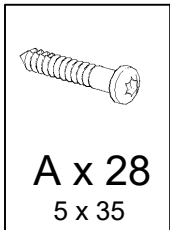
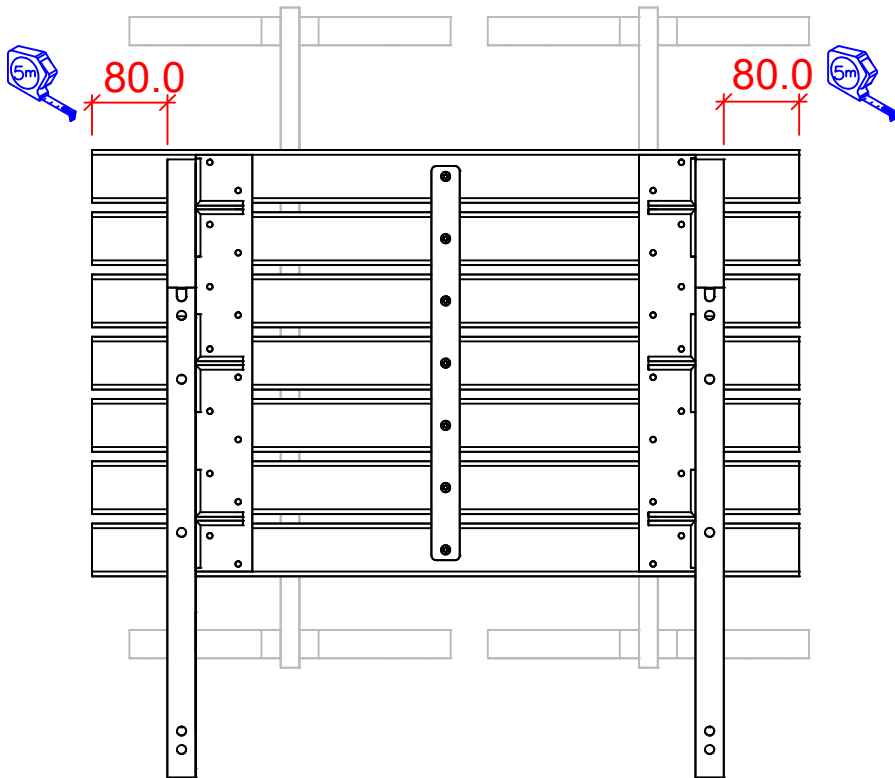

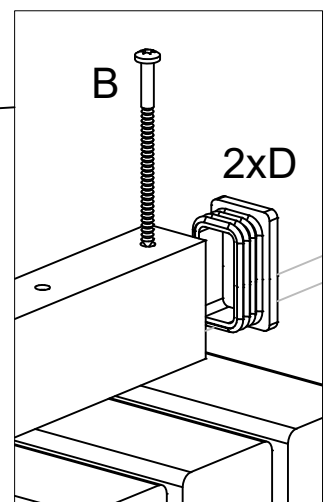
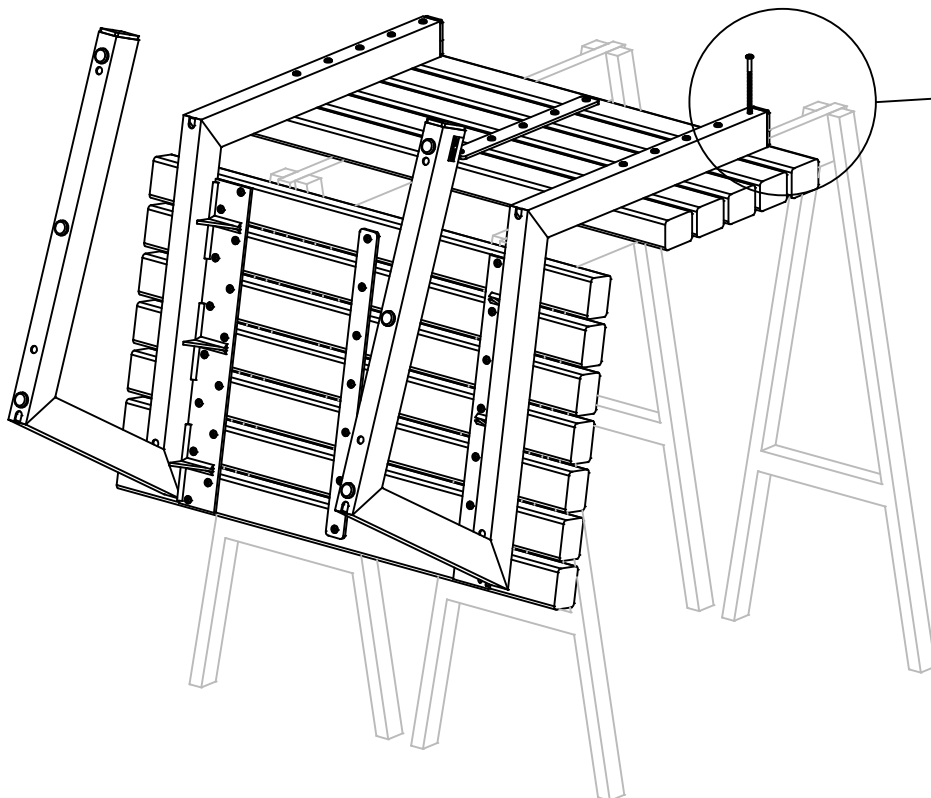
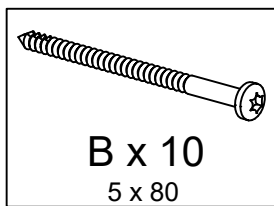
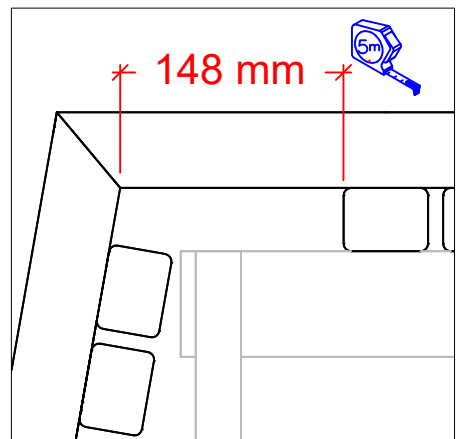
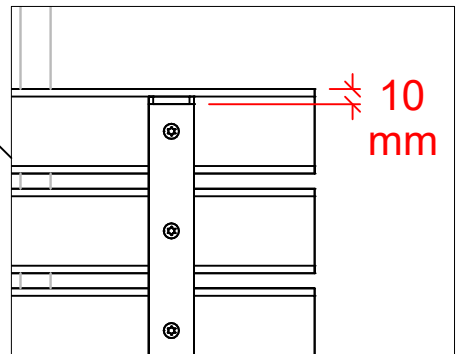
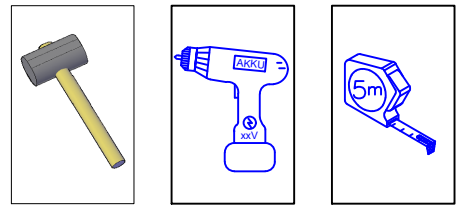
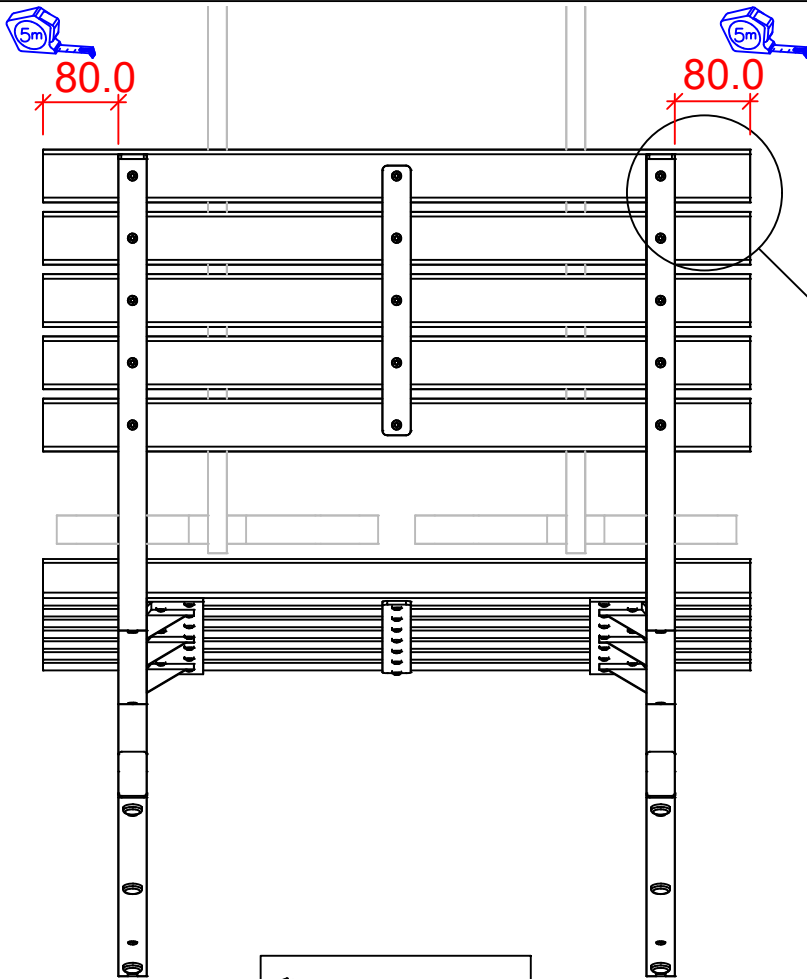

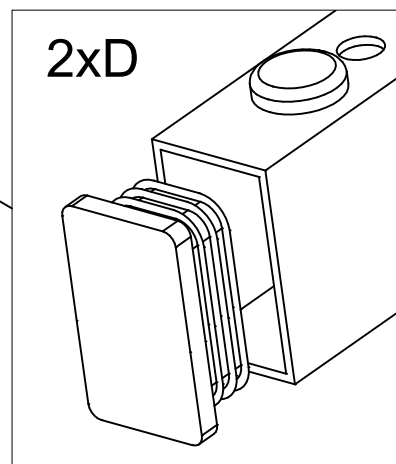
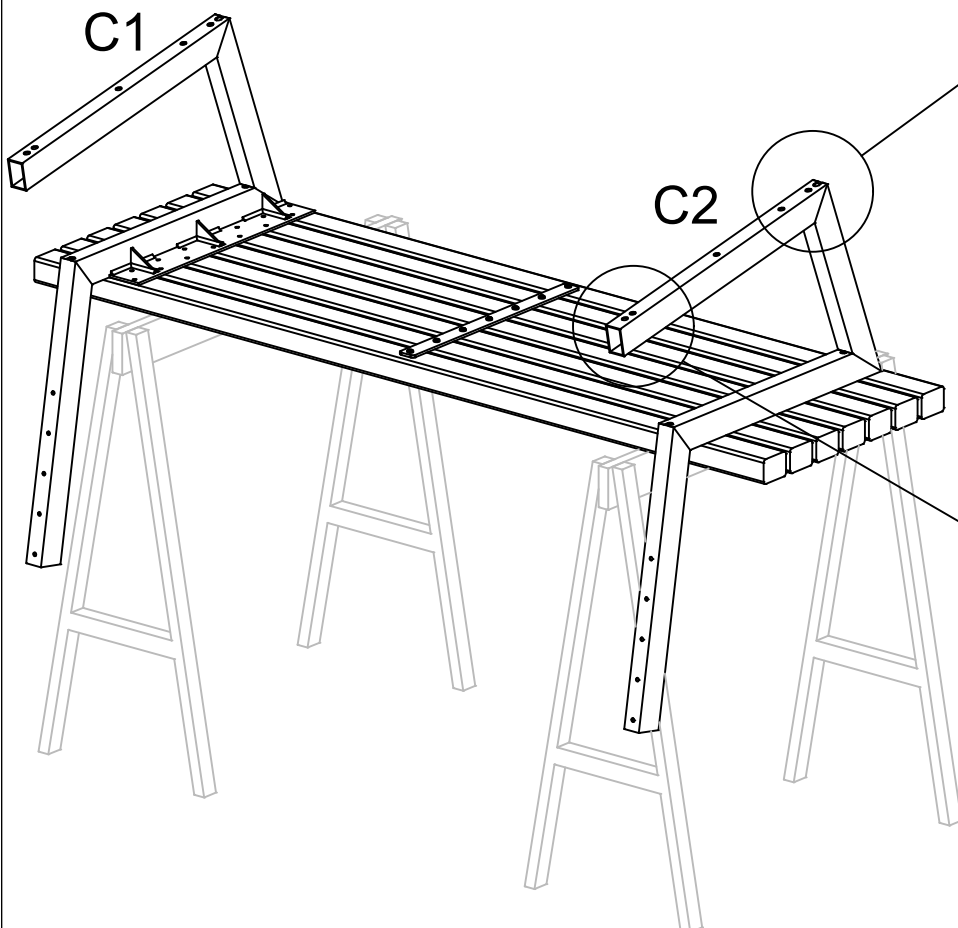
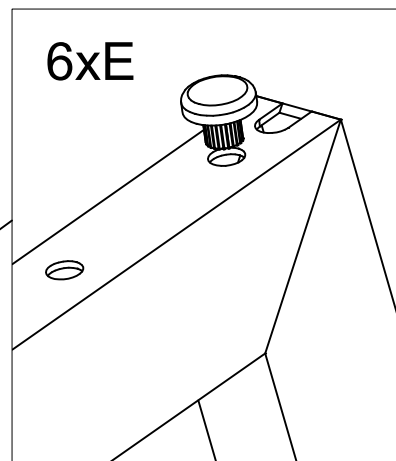
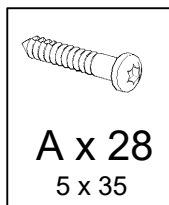
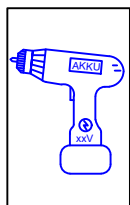
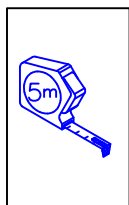
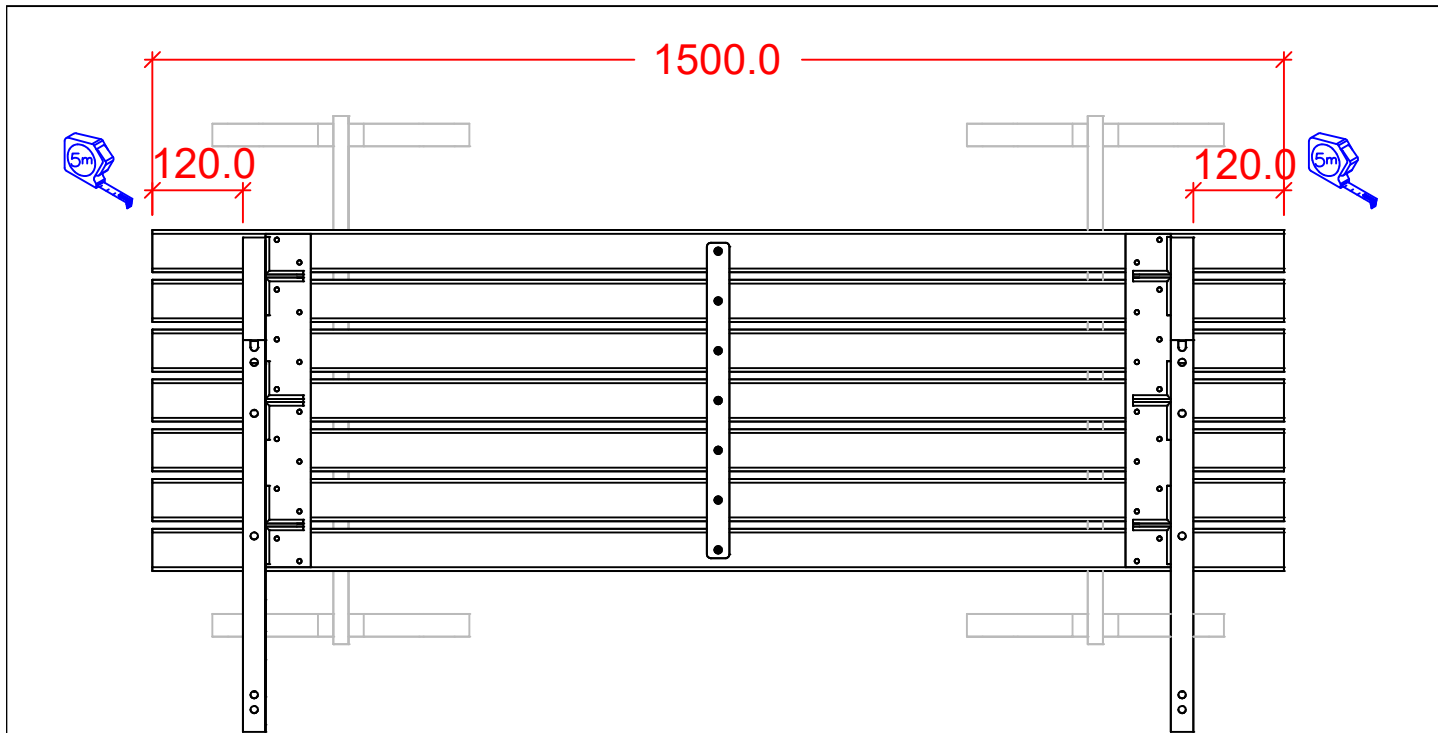

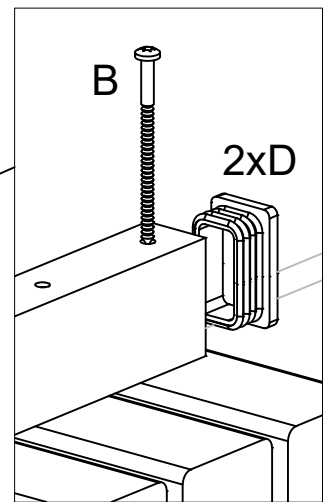
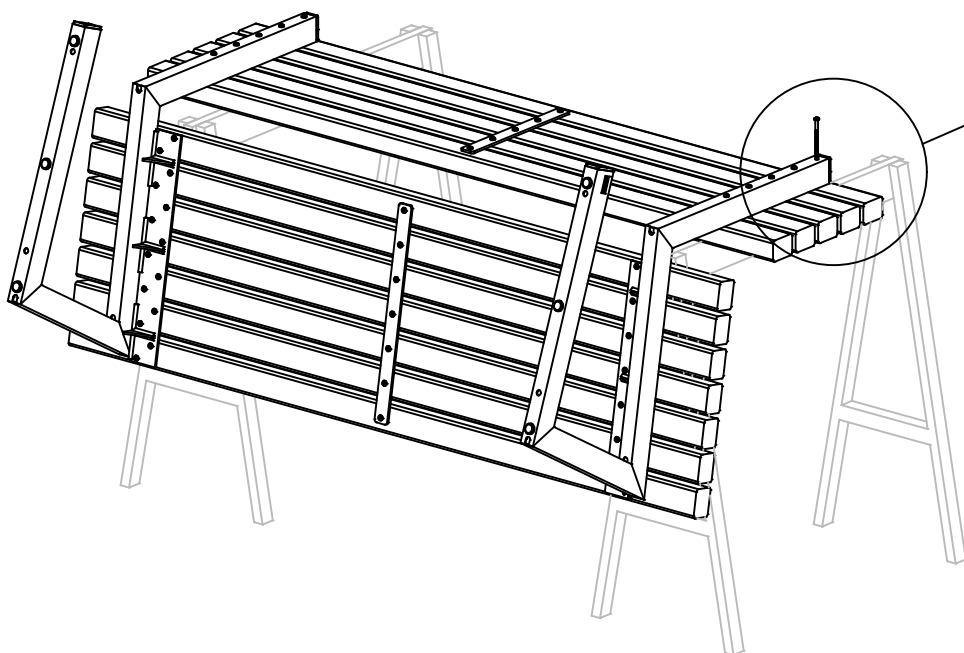
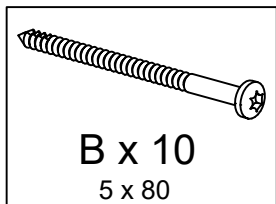
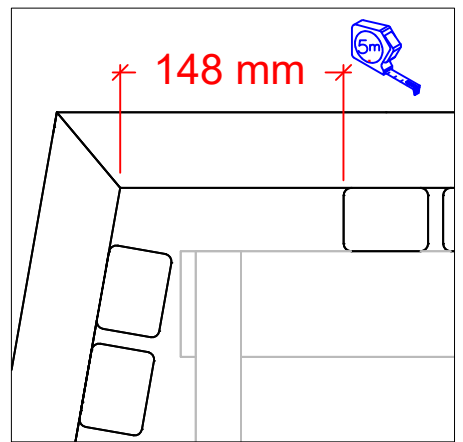
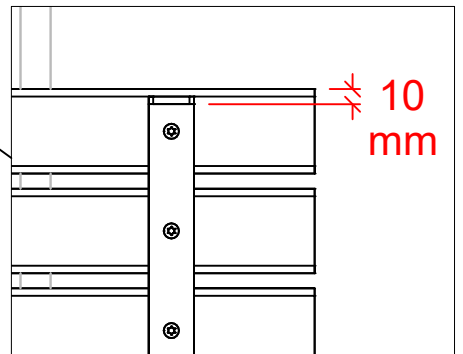
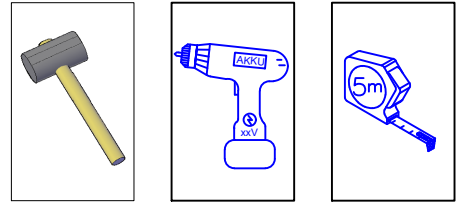
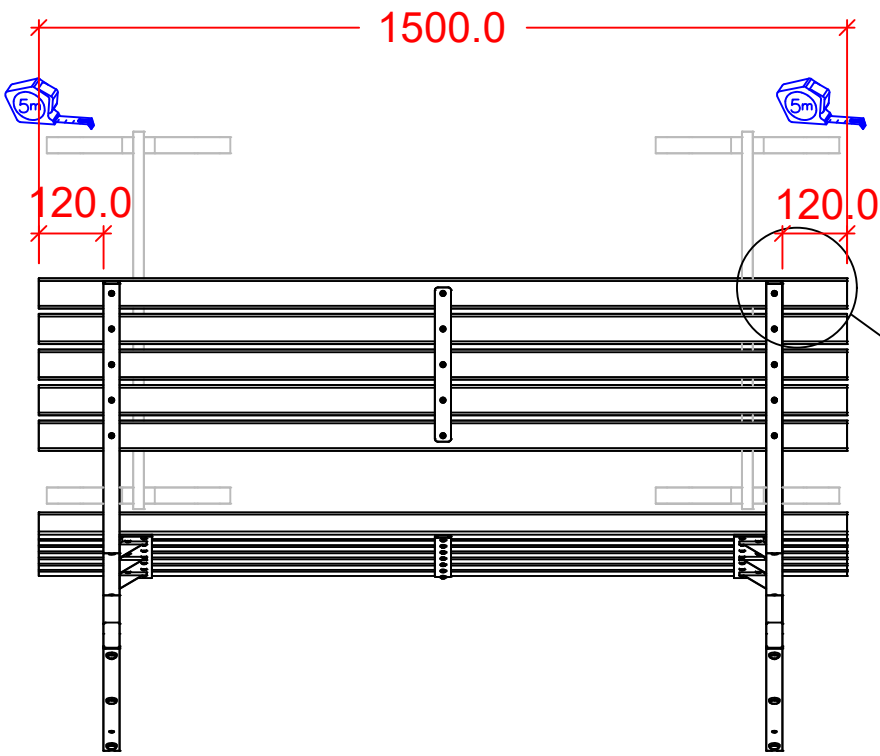

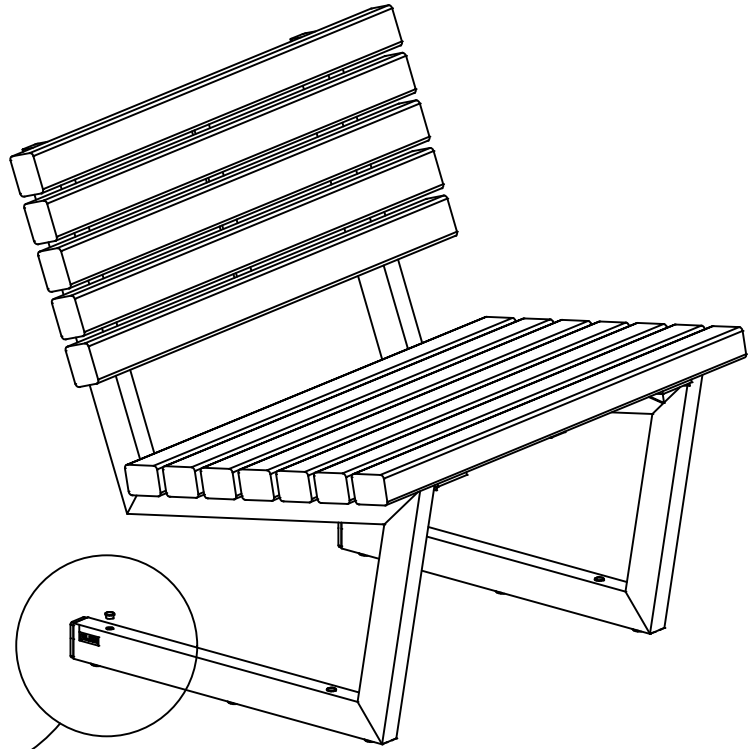
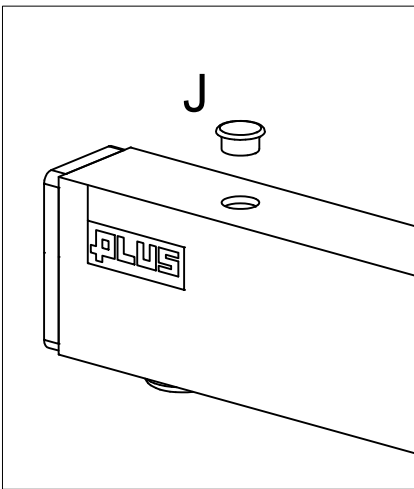
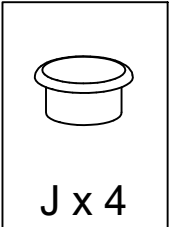
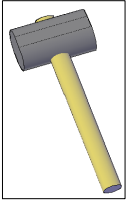

DK: Der medfølger 4 stk. propper.

Disse bruges til de gennemgående huller, såfremt bordet ikke skal fastgøres med bolte.

SE: 4 pluggar ingår.

Dessa används för de genomgående hålen om bordet inte ska fästas med bultar.

DE: 4 Dübel sind im Lieferumfang enthalten.

Diese werden für die Durchgangslöcher verwendet, wenn der Tisch nicht mit Bolzen befestigt werden soll.

UK: 4 plugs are included.

These are used for the through holes if the table is not to be secured with bolts.

FR: 4 bouchons sont inclus.

Ils sont utilisés pour les trous de passage si la table ne doit pas être fixée avec des boulons.

*Se næste side for fastgørelse.
Se nästa sida för fastsättning.
Zur Befestigung siehe nächste Seite.
See next page for fastening.
Voir page suivante pour la fixation.*

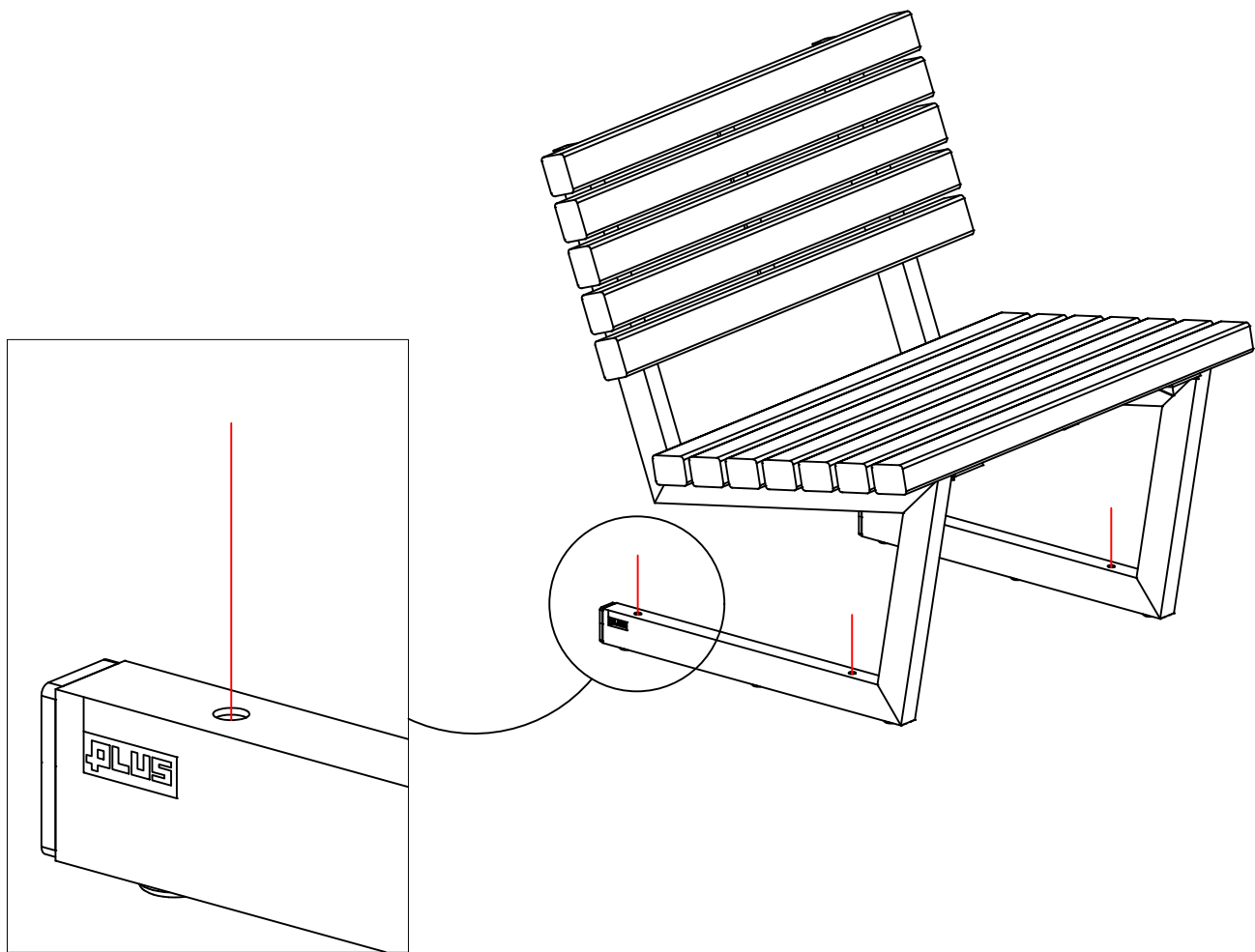

DK: De gennemgående Ø10 mm huller kan bruges til fastgørelse af stellet.
Med for eksempel en M8 mm bolt (Medfølger ikke).

SE: De genomgående hålen Ø10 mm kan användas för att fästa ramen.
Till exempel med en M8 mm bult (medföljer ej).

DE: Die Ø10 mm Durchgangslöcher können zur Befestigung des Rahmens verwendet werden.
Zum Beispiel mit einer M8 mm Bolzen (nicht im Lieferumfang enthalten).

UK: The Ø10 mm through holes can be used to attach the frame.
For example, with an M8 mm bolt (not included).

FR: Les trous traversants de Ø10 mm peuvent être utilisés pour fixer le cadre.
Par exemple, avec un boulon M8 mm (non inclus).

19650-4

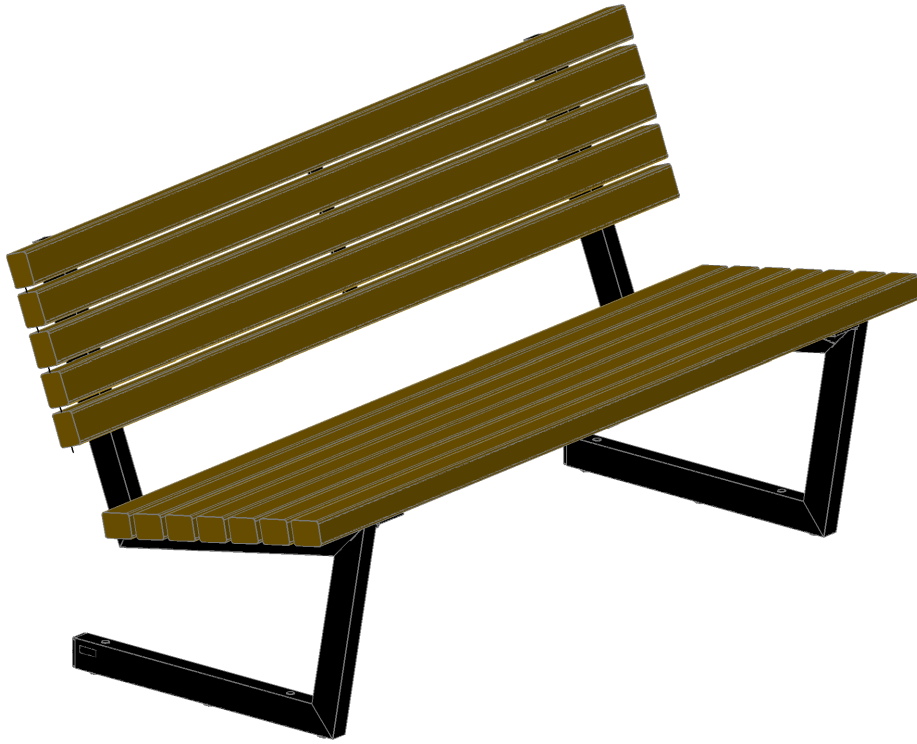

150 cm

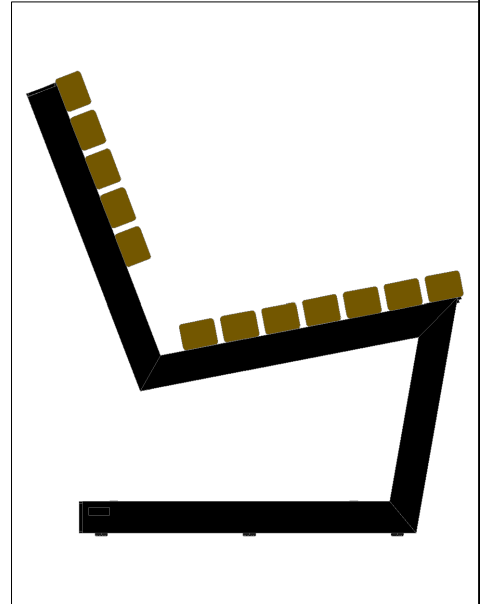

19652-4



75 cm

