



Morso 6170

- Ⓚ Opstillings- og betjeningsvejledning
- Ⓚ Instructions for installation and use



INDHOLD · CONTENTS

DK	1.0	Opstilling af Deres morsø ovn	5
	2.0	Fyringsteknik/Brugen af Deres ovn	10
	3.0	Regelmæssig vedligeholdelse af ovnen	14
	4.0	Tekniske data	17
UK	1.0	Installing your Morsø stove	21
	2.0	Firing/using the stove	26
	3.0	Routine stove maintenance	30
	4.0	HETAS admendments	34





By appointment to The Royal Danish Court

morsø

Opstillings- og betjeningsvejledning 6170



EN 13240 · SINTEF 110-0240

MORSØ JERNSTØBERI A/S · DK-7900 NYKØBING MORS
E-Mail: stoves@morsoe.com · Website: www.morsoe.com

Til lykke med Deres nye Morsø ovn!

Morsø, som er den største udbyder på det danske marked, har siden 1853 fremstillet brændeovne af den højeste kvalitet. Hvis De blot følger omstående instruktioner, er vi sikre på, at De også vil få nytte og glæde af Deres nye ovn i mange år.

Indhold

1.0	Opstilling af Deres morsø ovn	Side nr
1.1	Udpakning af ovnen	5
1.2	Opstilling af ovnen	5
1.3	Skorstensfejer	5
1.4	Ovnens placering/Afstandskrav	5
1.5	Skorstenen	6
1.6	Rørstilslutning	7
1.7	Montering af ovn	7
1.8	Tilslutning til stålskorsten	8
1.9	Trækforhold	9
2.0	Fyringsteknik/Brugen af Deres ovn	10
2.1	Optænding og fyringsintervaller	11
3.0	Regelmæssig vedligeholdelse af ovnen	14
3.1	Udvendig vedligeholdelse	14
3.2	Indvendig vedligeholdelse	14
3.3	Rensning af ovnen	15
4.0	Tekniske Data	17

Prøvningsattest - skal følge ovnen

Den danske Brændeovnsbekendtgørelse trådte ikraft den 1. januar 2008. I forbindelse med indførelsen af Brændeovnsbekendtgørelsen er det et krav, at der med brændeovnen følger en prøvningsattest, der er udstedt af det akkrediterede prøvningsinstitut, der har udført miljøafprøvningen på ovnen.

Prøvningsattesten er vedlagt i ovnen og skal opbevares af ejeren og følge ovnen i ovnens levetid.

Efter installation af brændeovnen og godkendelse af en skorstensfejer skal skorstensfejeren underskrive prøvningsattesten som dokumentation på, at ovnen opfylder miljøkravene i henhold til Brændeovnsbekendtgørelsen.

Ekstra tilbehør

Til Morsø ovnene tilbydes et omfattende skorstens-, gulvplade- og tilbehørsprogram, der kan lette den daglige betjening og vedligeholdelse af Deres Morsø ovn.

Støbejern

Støbejern er et levende materiale. Der er derfor ikke to ovne, der er helt ens. Det skyldes dels tolerancerne på støbejern, dels at ovnene er håndværksmæssigt udført.

1.0 Opstilling af Deres Morsø Ovn

1.1 Udpakning af ovnen

Morsø 6170 ovnen vejer 105 kg. For at undgå skamferinger i forbindelse med udpakning og montering af ovnen anbefales det at være 2 personer til dette arbejde.

Toppladen, der ligger løs, fjernes inden brændkammeret løftes af træpallen.

1.2 Opstilling af ovnen

Ovnen leveres med en medfølgende røgtud. Kuglespærren, der skal stoppe skorstensfejerens kugle under fejningen, er ligeledes vedlagt i ovnen, og monteres samtidig med monteringen af røgtuden, hvis ovnen monteres med røgafgang ovenud.

Man skal være opmærksom på nationale og lokale bestemmelser vedrørende opstilling af brændeovne. Samtidig skal man følge de lokale bestemmelser med hensyn til tilslutning til skorsten samt opstilling af skorstene. Spørg evt. Deres skorstensfejer til råds. Det er dog Dem selv, Deres tekniske rådgiver eller håndværker, der er ansvarlig for, at de nationale og lokale bestemmelser overholdes.

1.3 Skorstensfejer

Det kan, som nævnt, være klogt at rådføre sig med den lokale skorstensfejer inden ophængning af ovnen. Under alle omstændigheder skal skorstensfejeren underrettes, når brændeovnen er monteret. Skorstensfejeren foretager et check af installationen, og der aftales fejnings-terminer. Hvis skorstenen ikke har været i brug i nogen tid, bør den undersøges for revnedannelser, fuglereder m.v., inden den igen tages i brug.

1.4 Ovnens placering/Afstandskrav

Kun når ovnen placeres op ad brandbart materiale, stilles der krav til afstand. Afstand til brændbart materiale skal minimum følge nedenstående skema.

Min. afstand til brandbart materiale:

Ovn type	Bag ovnen (A)	Ved Ovnens sider (B)	Møbleringsafstand
Morsø 6170 uisoleret røgrør	150 mm	400 mm	900 mm

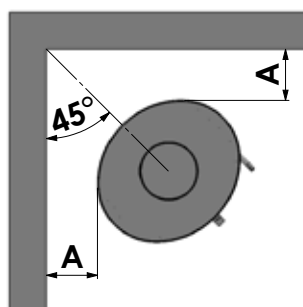
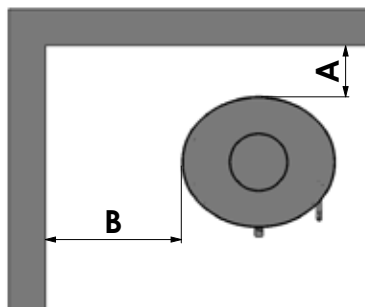

Montering over brændbart gulv

Monteres ovnen over brændbart gulv skal et ikke-brændbart underlag dække gulvet under ovnen og være mindst 30 cm. foran fyrdøren, og mindst 15 cm. til hver side af fyrråbningen

Bemærk: Min. afstand fra brændbart gulv til underside af ovn er 150 mm

Møbleringsafstand

Afstand til brændbart materiale foran ovnen er 900 mm, men man bør vurdere, om møbler og andet vil blive udtørret af at stå tæt på ovnen.

En brændeovn bliver varm under fyring. Der skal derfor udvises en fornøden forsigtighed, specielt i.f.m. børns kontakt med ovnen.

1.5 Skorstenen

Hvis lokale bestemmelser tillader det, kan ovnen tilsluttes en skorsten, hvortil der i forvejen er tilsluttet et andet lukket ildsted (f.eks. en anden brændeovn eller oliefyr). Men bemærk at en brændeovn ikke må tilsluttes samme skorsten som nye kondenserende oliefyr. Er De i tvivl bedes De kontakte Deres skorstensfejer.

Man skal være opmærksom på eventuelle krav til placering af røgrør, hvis to eller flere ildsteder tilsluttes samme skorsten.

Brændeovnen må aldrig tilsluttes en skorsten, hvor et gasfyr er tilsluttet.

En moderne effektiv ovn stiller større krav til Deres skorsten. Lad derfor skorstensfejeren vurdere skorstenen.

Skorstenens lysning skal følge de nationale og lokale bestemmelser. Men generelt bør lysningsarealet mindst være 175 cm² for brændeovne.

En for stor skorstenslysning bevirker, at der bruges for meget energi på at få opvarmet skorstenen til et acceptabelt træk. Er der tale om en muret skorsten med større lysning, anbefales det at isætte en isolerende skorstensforing med den rigtige diameter. Herved opnås et forøget træk og tillige en bedre fyringsøkonomi.

Der stilles ingen krav til nogen bestemt skorstenshøjde, men den skal være så høj, at trækforholdene er i orden og røgen ikke generer. Som hovedregel er trækforholdene tilfredsstillende, når skorstenen er 4 meter over ovnen og er ført mindst 80 cm over tagrygningen. Placeres skorstenen ved husets sider bør toppen af skorstenen aldrig være lavere end husets tagryg eller tagets højeste punkt. Bemærk, at der ofte gælder nationale og lokale bestemmelser med hensyn til placering af skorstene i forbindelse med stråtag. Se afsnittet trækforhold 1.9.

Skorsten og røgrør skal forsynes med renselemme. Størrelsen på renselemme i skorsten skal mindst svare til skorstenens lysningsareal.

Skorstenen skal være tilgængelig for udvendigt eftersyn, og der skal være mulighed for adgang til renselemme og til skorstenen, hvis den skal renses fra toppen (eks. stålskorstene).

1.6 Rørtilslutning

Den øverste støbte topplade løftes af ovnen.

Bemærk den runde støbte dækplade i toppladen skal forblive fastmonteret, hvis ovnen skal monteres med røgrør bagud og skrues af den øverste topplade, hvis røgrøret ønskes monteret ovenud.

Montering af røgtud ovenud

Ovnen er fra fabrikken forberedt til montering af den vedlagte røgtud (1) ovenud med vedlagte kuglefang og skruer. Kuglefanget, der skal forhindre at skorstensfejeren ødelægger ovnens røgledeplader under rensning, er den 145 mm lange stang, der er vedlagt.

Montering af røgtud bagud

Ønskes ovnen monteret med røgafgang bagud, afmonteres den runde bagplade, afmonteres den runde plade, der er fikseret med 2 skruer bag på ovnen. Pladejernsbrikken på den indvendige konvektionsbagplade slås ud med små kontante slag med en hammer ud for de små ”broer”, der holder brikken på plads. Det støbte dæksel fjernes fra bagpladen og monteres på toppladen. Røgtuden centrereres og skrues fast på ovnens bagside med de vedlagte lus og skruer. Kuglefanget skal ikke anvendes ved montering af røgtud bagud.

Placering af røgledeplader

Røgledepladerne (2) og (3), der er udført i vermiculite, er placeret ved modtagelsen.

Man skal sikre sig, at røgledepladerne er korrekt monteret inden en optænding af ovnen finder sted. (se skitse)

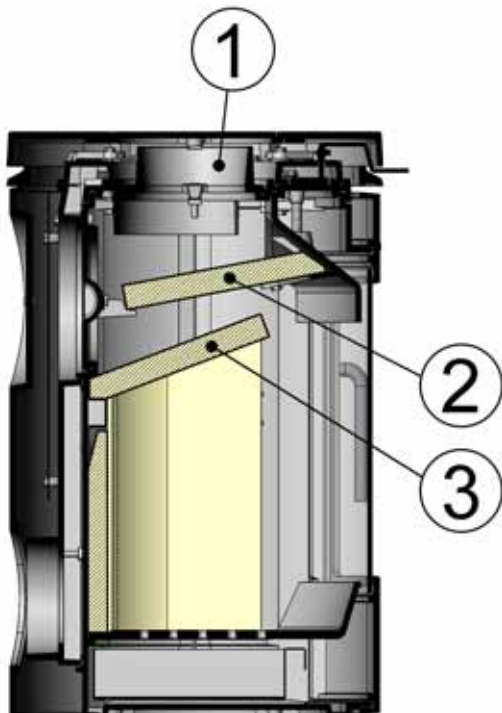

1.7 Montering af ovn

Vægbeslaget er leveret med 4 huller til montering af ekspansionsbolte i muren.

Boltene skal dimensioneres, så man er sikker på, at muren og det materiale den er udført i, er i stand til at holde ovnen. Ovnens egenvægt er 105 kg. Det påhviler derfor installatør/kunde at sikre sig at væg/skorsten på forsvarlig vis kan bære ovnen, vi gør opmærksom på at elementskorstene samt murede 1/2-stens skorstene uden foring ikke altid har den nødvendige bæreevne. Er de i tvivl skal De derfor kontakte en fagmand. Vægbeslaget, der er monteret på ovnen ved leveringen skrues af. Vægbeslaget kan benyttes som boreskabelon.

Bemærk, der må ikke anvendes rawplugs af plastik på grund af varmepåvirkning.

Vægbeslaget monteres på væggen og en murbøsning indmures korrekt (se skitse) hvis røgafgangen ønskes bagud.

Brændeovnen løftes på plads, så den støtter bunden af vægbeslaget og fastgøres igen til beslaget vha. de medfølgende skruer.

Tilslutning til muret skorsten

I væggen fastmures en røgrørsbøsning, og røgrøret føres ind i denne. Røret må ikke stikkes ind i selve skorstensåbningen, men kun gå til den indvendige side af skorstenslysningen.

Evt. overgang fra lodret til vandret røgrør kan med fordel monteres med en blød bøjning for at undgå tab af skorstenstræk.

Dimensioneringen af røgrør skal følge de nationale og lokale bestemmelser. Morsø anbefaler dog, at røgrør udføres i 2 mm stålplade, da det vil forlænge røgrørets levetid.

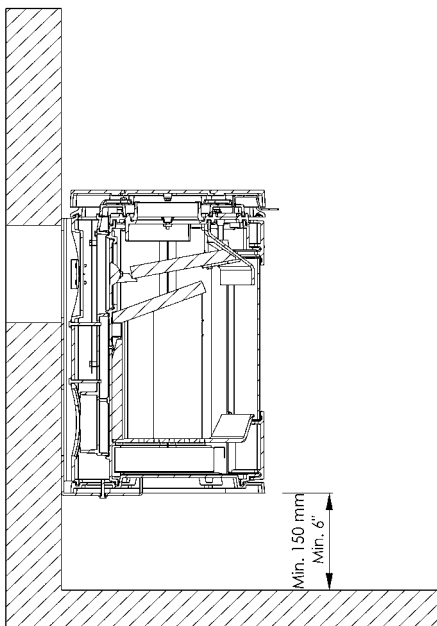

1.8 Tilslutning til stålskorsten

Er der tale om ophængning, hvor skorstenen føres direkte op gennem loftet, skal man følge de nationale og lokale bestemmelser m.h.t. skorstenens afstand til brandbart loft. Skorstenen tættes ved røgtuden med vedlagte glassnor. Det er vigtigt at skorstenen er monteret med tagbæring, så det ikke er ovnen der bærer skorstenen. (Se skorstensfabrikantens vejledning). En stor vægt på ovnens topplade kan forårsage revnedannelse af denne. Morsøs garanti omfatter ikke toppladen, hvis skorstenen er monteret uden tagbæring.

Skulle der opstå skorstensbrand i.f.m. fejlbetjening af ovnen eller længere tids anvendelse af fugtigt brændsel, lukkes lufttilførslen helt, og brandvæsnet kontaktes.

Bemærk: Det medleverede vægophæng er ikke dimensioneret til også at bære vægten af en tung skorsten.

Se skorstenfabrikantens vejledning.

Vær opmærksom på!

Rensningsmuligheder. Tal med skorstensfejeren.

Ved for lidt træk i skorstenen kan man med fordel montere røgrøret ovenud, da man derved mindsker røgvandringen i selve brændkammeret.

Undgå flere bøjninger end nødvendigt og begræns røgrørslængden, da trækforholdene ellers nedsættes.

Frisklufttilførsel

En brændeovn kræver luft til forbrændingen. Dette bevirker, at brændeovnsfyring er med til at give et sundt indeklima i et hus. Hvis huset er meget tæt, og især hvis der er emhætte eller ventilationsanlæg i huset, kan det være nødvendigt at anbringe en luftrist i det rum, hvor brændeovnen er opstillet. I modsat fald vil skorstenstrækket blive for svagt, hvilket kan medføre at ovnen ikke vil brænde ordentligt, og der kan komme røg ud af ovnen når fyrdøren åbnes. Er det nødvendigt at anbringe luftriste, skal de placeres således, at de ikke kan blokeres.

1.9 Trækforhold

Hvis der kommer røg ud af ovnen, når fyrdøren åbnes, skyldes det dårligt skorstenstræk. Der kræves, for denne ovntype, et skorstenstræk på mindst 12 pa. for at afgive tilfredsstillende forbrænding og forhindre røgudslip. Der vil dog være risiko for røgudslip, hvis ovndøren åbnes under meget kraftig fyring.

Røggasttemperaturen ved nominal ydelse er 281°C henført til 20°C.

Er De i tvivl, kan De eventuelt lade Deres skorstensfejer måle trækket i skorstenen.

Trækforhold

Skorstenens træk skabes på grund af forskellen mellem den høje temperatur i skorstenen og den koldere udetemperatur. Skorstenens længde og isolering, vind og vejrforhold er også afgørende for, at man kan opnå det rette undertryk, så trækket skabes.

Nedsat træk fremkommer når:

- Temperaturforskellen er for lille. Eksempelvis ved for dårlig isoleret skorsten. Hvis skorstenen er kold, kan det inden optænding hjælpe at antænde (afbluse) en sammenkrøllet avis i skorstenens rensedør.
- Udetemperaturen er for høj. Eksempelvis om sommeren.
- Det er vindstille.
- Skorstenen ikke har den rette højde, så den er i læ af tagflade og høje træer. I disse tilfælde er der også størst risiko for røgnedslag.
- Der kommer falsk luft ind i skorstenen. Eksempelvis gennem manglende fuger eller utætheder ved renselerm eller røgrør.
- Der er utætte ubenyttede ildsteder tilsluttet skorstenen.
- Røgrør og skorsten er tilstoppet af sod p.g.a. manglende rensning.
- Huset er for tæt (se afsnittet: Frisklufttilførsel).

Godt træk fremkommer når:

- Temperaturforskellen i skorstenen og udenfor er stor. Altså ved fyring, når behovet er størst.
- Det er klart i vejret og der er en god vind.
- Skorstenen har den rette højde. Min. 4 meter over ovnen og fri af tagryg.

2.0 Fyringsteknik/Brugen af Deres ovn

Deres ovn er konstrueret med lufttilførsel 2 steder.

En forvarmet forbrændingsluft tilføres forbrændingen med stor hastighed over glasset og betjenes ved hjælp af grebet over døren. Forbrændingsluften tilføres, når grebet skydes til højre og lukkes når grebet skydes til venstre.

En anden lufttilførsel er en konstant forvarmet lufttilførsel uden reguleringsmulighed, der tilføres forbrændingen lige over bålet, og sørger for at brænde de sidste gasser af, som træet afgiver under opvarmningen.

Ovnens nominelle varmeydelse er 5,9 kW.

Deres nye Morsø ovn er EN afprøvet til fyring med træ og egnet til intermitterende brug.

VIGTIGT!

Træ er et yderst gasholdigt materiale (ca. 75 %). Disse gasser frigives under opvarmning og antændelse af træet. Det er derfor vigtigt at disse gasser antændes hurtigt efter en påfyldning. Ligger træet kun og ulmer, specielt efter en ny påfyldning, giver det en kraftig røgudvikling, som i værste fald kan forårsage en eksplosionsagtig antændelse af gasserne med skader på ovnen til følge.

For at kunne antænde disse frigivne gasser fra træet og opretholde klare og blivende flammer i forbrændingsforløbet, er det derfor vigtigt altid at tilføre den nødvendige mængde ilt (luftmængde).

Indstilling af lufttilførsel, optændingsmetode og fyringsintervaller er afhængig af skorstenstræk, vind- og vejrforhold, varmebehov, brændsel m.m. Derfor kan der gå tid, inden De kender ovnens korrekte funktion under de givne forhold.

Selv om der kan fyres med næsten alle former for træ i Deres Morsø ovn, skal man ikke fyre med vådt eller ulagret træ. Træ bør under tag lagres mindst 1 år og helst 2 år med fri adgang for vind. Træ skal kløves hurtigst muligt efter fældningen, hvis det skal tørre hurtigt. Træet kan anvendes, når fugtigheden er under 20%. Under EN afprøvningen testes alle brændeovne med træ der har et fugtindhold på $(16 \pm 4)\%$.

Brug aldrig drivtømmer, da det som regel er meget saltholdigt, og ødelægger dermed både ovnen og skorsten. Imprægneret og malet træ samt spånplader udsender giftig røg og dampe og må derfor heller ikke anvendes som brænde.

Bemærk, der må ikke anvendes flydende brændsel i ovnen.

Brændestykker med en diameter større end 10 cm bør altid kløves. Brændestykkerne må ikke være længere, end de kan ligge plant over glødelaget med luft til begge ender. Maximal brændelængde i ovnen er 30 cm.

Maximal brændemængde er ca 2 kg./time (max. 2 stykker træ pr. påfyldning).

De første optændinger skal være moderate, således at den varmebestandige maling kan hærdes, inden der fyres kraftigere. Malingen kan i hærdningsfasen udvikle røg og lugtgener under den første optænding, hvilket er ganske normalt. Sørg derfor for udluftning i denne periode.

2.1 Optænding og fyringsintervaller

Under optænding er der behov for en stor luftmængde. Startes der op med en helt kold ovn, kan man med fordel lade døren stå på klem de første minutter og åbne forbrændingslufttilførsel på max. For at opbygge et isolerende askelag i bunden af ovnen, bør De ved første optænding afbrænde 1-1,5 kg tørt pinebrænde.

Behold herefter altid 1 cm aske i bunden af brændkammeret.

1. Glødelaget dannes hurtigt ved optænding med 2-4 optændingstabletter eller 7-10 sammenkrøllede avissider under ca. 1-1,5 kg tørt pinebrænde.



2. Der åbnes helt for lufttilførslen, der betjenes med grebet over døren.



3. Efter antænding af papiret/sprittabletterne lukkes døren på klem, så der er godt med træk ved en åbning på ca. 5-10 cm.



4. Når man kan se (efter 5-10 min.), at skorstenen er så varm, at der er træk igennem den, lukkes døren helt. Hvis alle forudsætninger er opfyldt, vil der efter yderligere ca. 15-20 min. være dannet et pænt glødelag i brandkammeret.



5. Normal påfyring bør ske, mens der endnu er gløder tilbage. Gløderne fordeles i bunden, dog flest foran i ovnen.



6. Der lægges 2 stykker brænde à ca. 0,7 kg og ca. 25-30 cm lange ind over gløderne i ét lag med en afstand på ca. 1 cm mellem træstykkerne.



7. Når lufttilførselen er åbnet på max. og døren lukkes, vil den friske træ mængde være antændt på et par minutter.



8. Herefter justeres forbrændingsluften ned til den ønskede position, og den optimale forbrænding vil fortsætte til grundglød. Under den nominelle afprøvning lå påfyldningsintervallet på 60-70 minutter.



9. En ny portion træ kan påfyres på samme måde som angivet i pkt. 5 & 6.



Normalt skal ovndøren altid åbnes roligt de første 2-3 centimeter, og man skal vente til trykket er udlignet inden døren åbnes helt. På denne måde undgås eventuelle røggener specielt i forbindelse med dårlige trækforhold.

Åbn aldrig ovndøren under voldsom fyring.

Når træet er brændt ud, er det omdannet til glødende trækul. Hvis der så forinden er dannet et godt glødelag oven på et tilstrækkeligt lag aske, kan ovnen holde sig varm meget længe ikke mindst i kraft af støbejernets gode egenskaber.

Natfyring frarådes på det kraftigste. Det sviner miljøet og giver en ringe udnyttelse af brændet, da træets gasser med den lave temperatur ikke antændes. Istedet sætter det sig som sod (uforbrændte gasser) i skorstenen og i ovnen. Under ekstreme forhold såsom dårligt skorstenstræk, stor mængde træ eller vådt træ kan en eksplosionsagtig antændelse i værste fald forekomme.

Ved fyring om sommeren, når behovet for varme er minimal, bliver forbrændingen dårlig. Ovnen varmer for meget og man skruer ned for forbrændingen. Men husk altid at sørge for at der er blivende flammer, så længe træet ikke er omdannet til trækul. Ønsker De at fyre svagere gøres dette ved at påfylde mindre mængde træ.

Hvis man fyrer med vådt brænde, vil en stor del af brændets varmeenergi medgå til at fortrænge vandet fra brændet, uden at afgive varme til ovnen. Denne ufuldstændige forbrænding medfører sodaflejring i ovn, rør og skorsten.

Sammenligning træfyring og olie:

Træart (vandindhold på 20%)	Antal rummeter pr. 1000 l. olie
Eg	7,0
Bøg	7,0
Ask	7,2
Ær	7,5
Birk	8,0
Elm	8,9
Rødgran	10,4
Ædelgran	10,9

3.0 Regelmæssig vedligeholdelse af ovnen

3.1. Udvendig vedligeholdelse

Ovnens støbte overflade er malet med en varmebestandig senotherm maling. Den holder sig pænest, hvis den blot støvsuges med et blødt mundstykke eller aftørres med en tør frugfri klud.

Den malede overflade kan med tiden, ved for kraftig fyring, få et gråligt skær; men ovnen kan let opfriskes med en Morsø spraymaling, der kan købes hos Deres lokale forhandler. Morsø ovnene er malet med Morsø koks eller Morsø lys grå. Kan købes i spray eller dåse.

3.2 Indvendig vedligeholdelse

Glas

Ved korrekt fyring med træ afsættes der ingen, eller kun lidt sod, på det keramiske glas. Er der under optændingen sket soddannelse på glasset, vil soden brænde væk, når der fyres normalt i ovnen. Bliver glasset sodet grundigt til ved fejlbetjening, kan det let fjernes med f.eks. Morsø Glasrens. Glasset skal være koldt, når denne rengøring finder sted. Man skal undgå at fylde ovnen med så lange stykker brænde, at det presser på glasset, når lågen lukkes.

Årsager til sodet glas:

- For vådt brænde.
- For store stykker brænde/ukløvet træ.
- For lav forbrændingstemperatur.

Udskiftning af glas

Keramisk glas kan ikke genanvendes, fordi det har en højere smeltetemperatur. Blandes keramisk glas med almindelig glas, ødelægges råvaren og genvindingsprocessen af glas kan stoppe. Sørg for at det ildfaste glas ikke havner som almindelig genbrug. Det er til stor hjælp for miljøet.

OBS: Skal afleveres som keramisk glas på en genbrugsstation.

Indvendige støbejernsdele/og andre sliddele

Røgledeplader og andre dele, som er i direkte berøring med ild og glødende brændsel, er sliddele. De vil derfor være særlig udsat for gennembrænding. Ved korrekt brug vil disse dele holde i mange år. Ved for kraftig fyring vil gennembrændingen selvfølgelig fremskyndes. De nævnte dele kan udskiftes. Hvis røgledepladerne beskadiges og ikke skiftes i tide, vil toppladen herefter være udsat for så høj temperatur, at den kan tage skade.

Bemærk, at konstruktionen ikke må ændres, og dele, der udskiftes skal være originale MORSØ dele.

Årsager til for hurtig slitage af indvendige dele

- For kraftig fyring
- Brug af for meget tørt træ (møbelaffaldstræ).
- For meget sod ovenpå røgledepladerne (se afsnit Rensning).
- For meget aske i skuffen (se afsnit Aske).

Pakninger

Med tiden vil pakningerne i lågerne blive slidte og bør, for at undgå løbsk forbrænding, udskiftes efter behov. Brug Morsø pakningssæt

Bemærk: Normale sliddele er ikke omfattet af Morsøs udvidede garantiordning.

Vedligeholdelsessortiment (Reservedele, Glasrens, Maling, Pakningssæt m.m.) findes hos Deres Morsø forhandler.

3.3 Rensning af ovn

Specielt på oversiden af den øverste røgledeplade vil der, som følge af trækket i skorstenen og efter en fejning, komme et aske- og sodlag. Asken vil have en isolerende virkning, hvilket kan fremskynde en gennembrænding af røgledepladerne.

Under normal rensning kan røgledeplader tages ud af ovnen. Når disse er fjernet, giver det adgang til rensning af røggammeret over røgledepladerne.

Røgledeplader rengøres inden genmonteringen, hvor man skal sikre sig, at disse bliver korrekt monteret.

I dag skal skorstensfejeren, udover fejning af skorsten og rensning af røgrør, sørge for tømnings af sod i ovnen. Antallet af fejninger/rensning af ovnen vurderes af skorstensfejeren efter samråd med Dem.

Aske

Som tidligere beskrevet bør der være ca. 1 cm isolerende askelag i bunden af brandkammeret, for at opnå en høj forbrændingstemperatur. Når askelaget er for tykt, fejes asken ned i askeskuffen.

Tøm skuffen før den er helt fyldt, så asken ikke isolerer omkring risten, da det kan fremskynde en gennembrænding.

Asken må i de fleste tilfælde bortskaffes med dagrenovationen. Da der kan ligge gløder gemt i askeskuffen i flere døgn, kan det være nødvendigt at opbevare asken i en beholder af ubrændbart materiale, inden asken hældes i affaldssækken.

Aske fra en brændeovn kan ikke gavne haven som gødning. Hvis der har været afbrændt farvelagte brochurer, malet eller imprægneret træ og lignende i ovnen, må asken ikke hældes ud på jord, da den kan indeholde tungmetaller.

1. Nederste røgledeplade løftes en smule og holdes i den position. Derved løsnes sidestene.



2. Første sidesten vippes og tages ud.



3. Anden sidesten vippes og tages ud.



4. Efter at sidestenen er fjernet sænkes nederste røgledeplade og løftes ud.



5. Øverste røgledeplade løftes ud af sin holder og vippes ud.



6. Man skal sikre sig, at røgledeplader og sten igen er korrekt monteret inden optænding efter en rensning.



Vedligeholdelsesdele til 6170

Beskrivelse	Produktnr.
Mellembund	34611000
Røgledeplade øverst	79610600
Røgledeplade nederst	79610500
Tertiær boks	71610561
Glas	79610100
Sidesten højre	79610200
Sidesten venstre	79610300
Bagsten	79610400

4.0 Tekniske Data

Ovn model	Morsø 6100
CO emission (ved 13 % O ₂) (%)	0,03
OGC (tjære o.l.) emission (mg/m ³)	27
Partikel emission, vægtet gennemsnit (g/kg)	2,8
Partikel emission, maks. i enkel prøvning (g/kg)	5,3
Virkningsgrad (%)	80
Nominel drifteffekt (kW)	5
Røgtræk, minimum (Pa.)	12
Brændsel	Træ

Alle måledata i henhold til prøvestandarder EN 13 240 samt NS 3058-3059. Prøvninger er foretaget hos akkrediteret prøvningsinstitut.

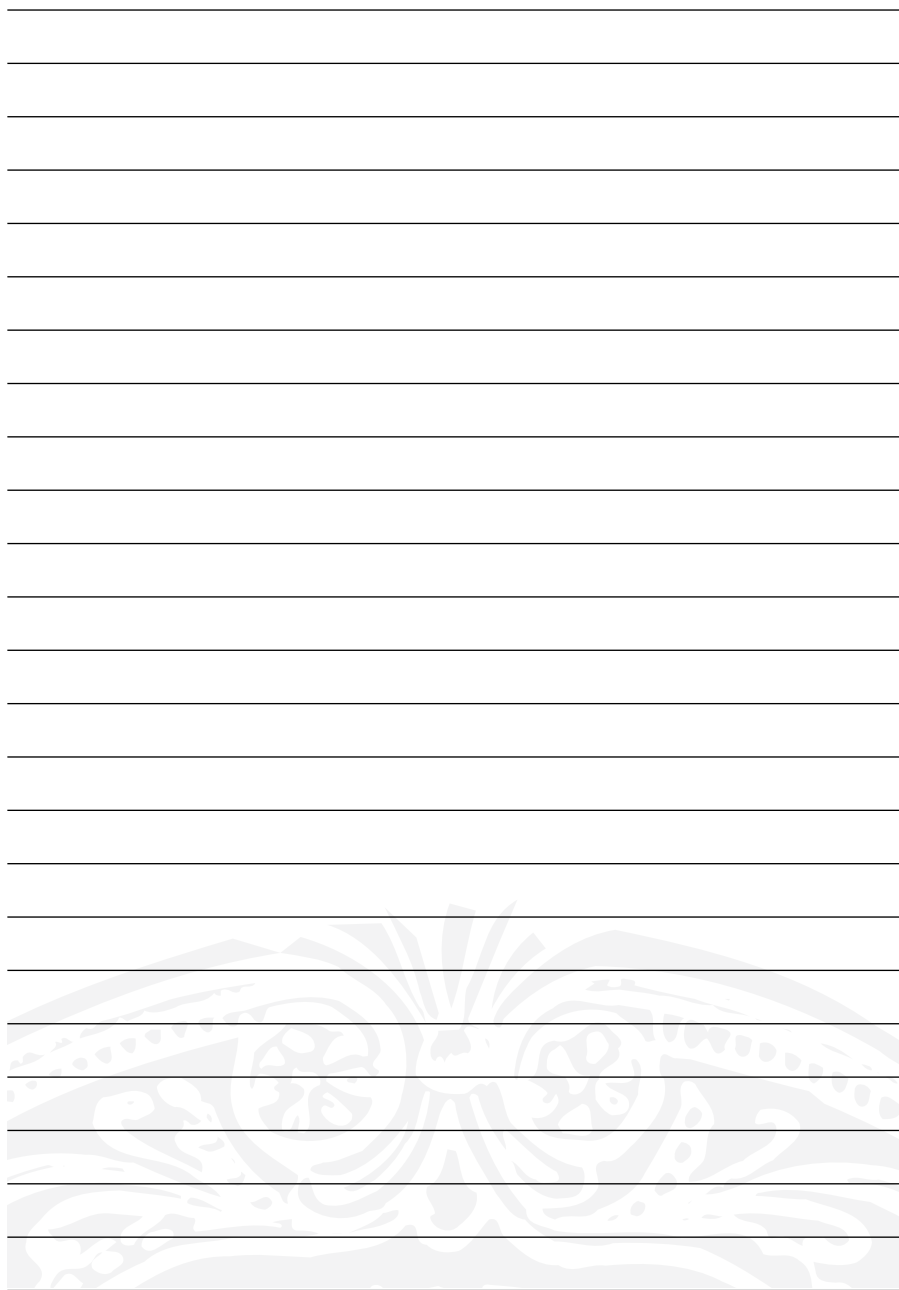



By appointment to The Royal Danish Court

morsø

Instructions for installation and use

6170



EN 13240

DEFRA approved for use in United Kingdom smoke control areas

MORSØ JERNSTØBERI A/S . DK-7900 NYKØBING MORS
E-Mail: stoves@morsoe.com · Website: www.morsoe.com

Enjoy your new Morsø stove!

Morsø, the biggest stove company in the Danish market, has been making wood-burning stoves of the highest quality since 1853. Just follow the instructions below, and we are certain that you will be able to use and enjoy your new stove for many years.

Contents

1.0	Installing your Morsø stove	Page no
1.1	Unpacking the stove	21
1.2	Installing the stove	21
1.3	Chimney sweep	21
1.4	Location of the stove/distance requirements	21
1.5	The chimney	22
1.6	Pipe connections	22
1.7	Installing the stove	23
1.8	Connecting to a steel chimney	24
1.9	Draught	25
2.0	Firing/using the stove	26
2.1	Lighting instructions and fuelling intervals	27
3.0	Routine stove maintenance	30
3.1	External maintenance	30
3.2	Internal maintenance	30
3.3	Cleaning the stove	31
4.0	HETAS amendments	34

Additional accessories

We offer a comprehensive line of chimney, floor plate and accessory products that can facilitate the daily operation and maintenance of your Morsø stove.

Cast iron

Cast iron is a live material. There are no two ovens that are identical. This is partly due to the tolerances of the casting process, partly because the ovens are a work of craftsmanship.

1.0 Installing your Morsø stove

1.1 Unpacking the stove

The Morsø 6170 stoves weigh 105 kg. In order to avoid damage when unpacking and assembling the stove, we recommend that this job be undertaken by 2 people.

Remove the top cover, which is lying loose, before lifting the combustion chamber off the wooden pallet.

1.2 Installing the stove

The stove comes with a smoke outlet included. The ball blocking device that is to stop the chimney sweep's ball during sweeping is also supplied with the stove and is installed at the same time as the smoke outlet if the stove is installed with a top flue exit.

National and local regulations regarding the installation of wood-burning stoves must be observed, as must local regulations regarding chimney connections and chimney installation. You may want to ask your chimney sweep for advice. However, you, your technical adviser or workman are responsible for complying with the applicable national and local regulations.

1.3 Chimney sweep

As stated, it may be wise to consult your local chimney sweep before wall mounting the stove. In any event, the chimney sweep must be notified once the wood-burning stove has been installed. The chimney sweep will inspect the installation and schedule sweeping intervals with you. If your chimney has not been used for some time, it should be inspected for cracks, bird nests, etc., before it is used.

1.4 Location of the stove/distance requirements

A safety clearance requirement applies only if the stove is placed next to combustible materials. The clearance to combustible materials must meet the minimum requirements in the following table:

Minimum distances from flammable material:

Type of stove	Behind the stove (A)	To the sides of the stove (B)	To furniture
Morsø 6170 stove uninsulated flue pipe	150 mm	400 mm	900 mm

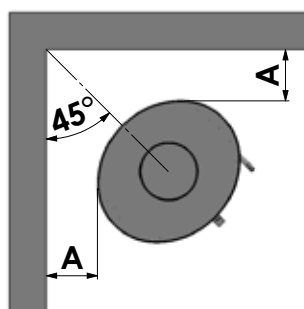
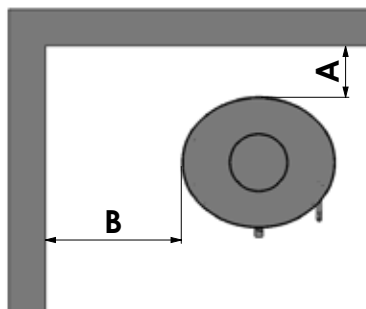

Combustible floor

If the stove is installed over combustible flooring, a non-combustible floor protection must cover the floor under the stove and extend at least 30 cm (12 inches) beyond and at least 15 cm (6 inches) to each side of the fuel door.

Note: The minimum clearance from a combustible floor to the underside of the stove is 150 mm (6 inches)

Distance to furniture

Clearance to combustible material in front of the stove is 900 mm (36 inches). However, consider if furniture etc. is dried out by being close to the stove.

A wood-burning stove gets hot when it is fired. Caution must therefore be observed, particularly with regard to children touching the stove.

1.5 The chimney

If local regulations permit, the stove may be connected to a chimney already serving another fireplace (such as an oil-burning stove or another wood-burning stove). Attention should be paid to any requirements concerning the location of flue pipes if two or more fireplaces are connected to the same chimney.

The wood-burning stove must never be connected to a chimney to which a gas-burning stove is already connected. An efficient, modern stove places great demands on the chimney, so have a chimney sweep check the condition of your chimney.

The aperture of the chimney must comply with national and local regulations. In general, the aperture area should measure at least 175 cm² for wood-burning stoves.

An overly large chimney aperture will mean that too much energy will be required to heat the chimney sufficiently to achieve an acceptable draught. If you have a brick chimney with a large aperture, we recommend that you install an insulating chimney liner of the proper diameter. This will increase the draught, and improve the fuel economy.

There are no requirements with respect to specific chimney heights, but a chimney must be tall enough to provide a good draught, and to ensure that the smoke does not cause any problems. As a general rule, there will be a satisfactory draught if the chimney extends 4 metres above the stove and at least 80 cm above the spine of the roof. If the chimney is located along the side of the house, the top of the chimney should never be lower than the spine of the roof or the highest point on the roof. Please note that there are often national and local regulations regulating the location of chimneys in houses with thatched roofs. Please see section 1.9 Draught.

The chimney and the flue pipe must be fitted with cleaning doors, which must be at least the same size as the chimney's aperture area.

The chimney must be accessible for external inspection, and it must be possible to access the cleaning doors and the chimney if it is to be cleaned from the top (e.g. steel chimneys).

1.6 Connecting the flue pipe

Lift the upper cast iron top plate off the stove.

Note: the round cast iron cover plate in the top plate must remain mounted if the stove is being installed with the flue pipe to the rear, but unscrewed from the upper top plate if the flue pipe is being installed pointing upwards.

Mounting the flue collar pointing upwards

From the factory, the stove is prepared for installation with the included flue collar (1) pointing upwards with included ball stop and screws. The ball stop, which prevents the chimney sweep from damaging the stove's baffle plates while sweeping, is the 145 mm long rod that is provided.

Mounting the flue collar to the rear

If the stove is being installed with the flue pipe to the rear, the round plate fixed with two screws on the back of the stove is dismantled. The iron piece on the inside convection back panel is knocked out with light, firm taps with a hammer next to the small "bridges" holding the piece. The cast iron cover is removed from the back panel and mounted on the top plate. The flue collar is centred and screwed onto the back of the stove with the clamps and screws provided. The ball stop is not used when installing the flue collar to the rear.

The location of the baffles

The baffles (2) and (3), which are made from vermiculite, are mounted at the factory.

Make sure that the baffles are correctly assembled before lighting the stove (please see the sketch).

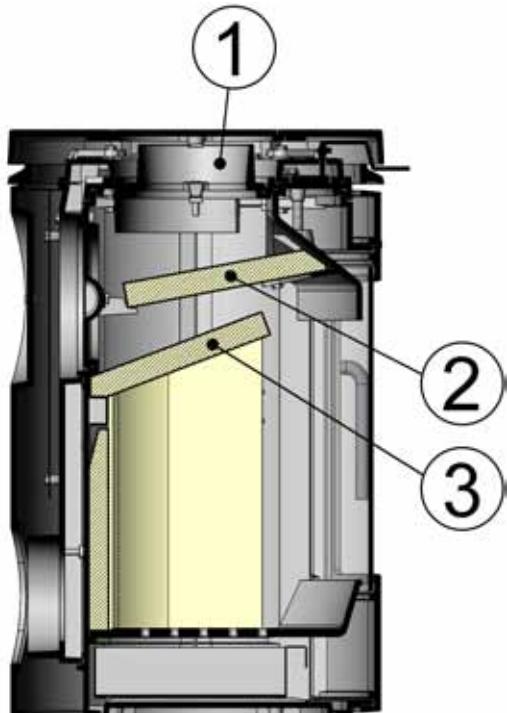

1.7 Installing the stove

The wall-mounting frame has four holes for mounting expansion bolts into the wall.

The bolts must be adequately sized and you must ensure that the wall is capable of supporting the stove. The weight of the empty stove is 105 kg (232 lbs). The stove must not be installed on element block chimneys such as thermalite blocks, pre cast flues or similar structures. The wall mounting frame may be used as a template for drilling.

Note: Plastic rawplugs must not used due to the heat produced by the stove.

Mount the wall-mounting fixture on the wall. If the flue exit is wanted to the rear, build a wall bushing correctly into the wall (see illustration).

Lift the wood stove in place so that it rests on the bottom part of the wall-mounting fixture, and secure it again to the fixture by means of the screws included.

Connecting to a brick chimney

Build a flue pipe bushing into the wall, and insert the flue pipe. The pipe must not extend into the chimney itself but only to the edge of the chimney aperture.

A soft bend of a transition from a vertical to a horizontal flue pipe, if required, is beneficial to reduce loss of chimney draught.

Flue pipe sizing must be in accordance with national and local regulations. Morsø recommends, however, that flue pipes be made of 2 mm sheet steel, because it will extend the life of the flue pipe.

1.8 Connecting to a steel chimney

If your installation involves routing the chimney straight up through the ceiling, it must comply with national and local regulations concerning the distance of the chimney from flammable ceiling material. The chimney must be sealed at the smoke outlet using the glass tape provided. It is important to install the chimney with a roof support so that the stove does not bear the weight of the chimney. (See the chimney manufacturer's instructions). Heavy weights on the stove's top plate may cause it to crack. The Morsø warranty does not cover the top plate if the chimney is installed without a roof support. If a chimney fire should occur as a result of incorrect operation of the stove or prolonged use of wet fuel, close the vents completely and contact the fire brigade.

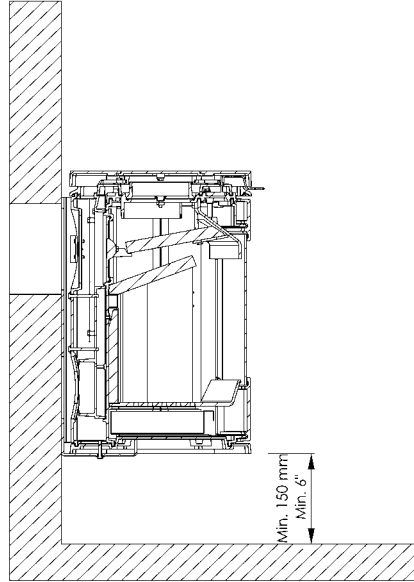

Note: The supplied wall-mounting fixture is not designed to carry the weight of a heavy chimney as well.

Refer to the guidelines from the chimney manufacturer.

Be aware of the following:

Discuss the cleaning options with your chimney sweep.

If there is insufficient draught in the chimney, it may be a good idea to install the flue pipe straight up so as to minimise smoke migration in the actual combustion chamber.

Avoid having more bends than necessary, and limit the length of the flue pipe so as not to reduce the draught.

Fresh air supply

A wood-burning stove requires air for combustion. As a result, firing a wood-burning stove will help create a healthy climate in your house. If the house is very tightly sealed, and particularly if there is a cooker hood or

ventilation system in the house, it may be necessary to install an air grate in the room in which the wood-burning stove is installed. Otherwise there may not be enough draught in the chimney, which may result in the stove not being able to burn properly, and smoke may come out of the stove when the fire door is opened.

If it is necessary to install air grates, they must be positioned so that they cannot be obstructed.

1.9 Draught

If smoke comes out of the stove when the fire door is opened, it will be due to the poor draught in the chimney. This type of stove requires at least 12 PA of chimney draught to achieve satisfactory combustion and to prevent smoke from escaping. Smoke may, however, escape in any event if the stove door is opened during vigorous firing, so this should be avoided.

The flue gas temperature at the rated output is 281 °C relative to 20 °C.

If in doubt, you may want to get your chimney sweep to measure the draught in the chimney.

Draught

The draught in the chimney is the result of the difference between the high temperature in the chimney and the cooler temperature outside. Other factors that determine whether sufficient negative pressure can be produced to create a draught include the length and insulation of the chimney, and wind and weather conditions.

The draught will be reduced when:

- The temperature difference is too low, e.g. in connection with a poorly insulated chimney.

If the chimney is cold, it may help to light (burn up) a rolled-up newspaper in the chimney's cleaning door.

- The outside temperature is too high, e.g. during the summer.
- There is no wind.
- The chimney is not tall enough, with the result that it sits in the lee of the roof surface or tall trees.

These conditions are also associated with the greatest risk of smoke coming back down the chimney.

- Air is entering the chimney in undesired places, e.g. through cracked joints or leaks in the cleaning door or the flue pipe.
- Unsealed, unused fireplaces are connected to the chimney.
- The flue pipe and chimney are clogged up with soot due to inadequate cleaning.
- The house is too tightly sealed (please see the section on Fresh air supply).

A good draught is achieved when:

- There is a big difference between the temperature in the chimney and outside, i.e. when the need for heating is greatest.
- The weather is clear and there is a good wind.
- The chimney is of the proper height, i.e. Minimum 4 metres above the stove, and clear of the spine of the roof.

2.0 Firing/using the stove

Your stove is constructed with air inlets in two places.

Pre-heated, fast-moving combustion air is added to the fire above the glass window, and is regulated using the handle above the door. The combustion air is let in when the handle is pushed to the right, and shut off when the handle is pushed to the left.

Another air inlet provides constant, pre-heated air supply which cannot be adjusted, and which comes into the combustion chamber just above the fire. This helps burn off the last few gasses emitted by the wood while it is being heated.

The stove's rated heat output is 5,9 kW.

Your new Morsø stove is EN-tested for firing with wood, and is suitable for intermittent use.

NB!

Wood is a material that contains a great deal of gas (approx. 75%). The gases are released when the wood is lit and heated. For this reason, it is important that these gases are ignited quickly after stoking. If the wood just lies smouldering, especially after re-stoking, a lot of smoke is created which, in the worst case, may cause an explosive ignition of the gases, resulting in damage to the stove.

In order to ignite the gases that are released from the wood, and to keep clear, lasting flames during the combustion process, it is important to let in the required quantity of oxygen (air supply) at all times. The setting of the air supply, the method of ignition and the lighting intervals depend on the draught in the chimney, the wind and weather, the amount of heat required, the fuel, etc. This means that it may take some time before you get to know the correct functioning of the stove under any given circumstances.

Although you can fire your Morsø stove with almost all kinds of wood, you should not fire with wet wood, or unseasoned wood. Wood ought to be stored under a roof for at least 1 year, and preferably 2 years, with free access to wind. Wood should be chopped as soon as possible after felling if it is to dry quickly. The wood can be used once the moisture is less than 20%. During the EN test, all stoves are tested with wood with a moisture content of $(16 \pm 4)\%$.

Never use driftwood as it usually has a high salt content, which damages both the stove and the chimney. Impregnated and painted wood and chipboard emit poisonous smoke and fumes so they should not be used as fuel either

Please note that liquid fuel may not be used in the stove.

Pieces of wood with a diameter exceeding 10 cm should always be chopped.

The pieces of wood should be short enough to be able to lie flat over the layers of embers, with air at both ends. The maximum length of fuel in the stove is 30 cm. The maximum quantity of fuel is approx. 2 kg/hour (max. 2 pieces of wood each time you re-stoke).

The first few times you light the stove, the fire should be moderate so that the heat-resistant paint can harden before firing more vigorously. During the hardening phase, the paint may develop obnoxious smoke and smell the first time it is lit, which is very normal. Make sure that the room is well ventilated during this period.

2.1 Lighting instructions and fuelling intervals

A lot of air is needed when lighting the stove. If you are starting with a cold stove, the door should be left ajar for the first few minutes and the combustion air supply opened to maximum.

In order to build up an insulating layer of ash in the bottom of the stove, you should burn 1-1.5 kg of dry kindling when you light the stove the first time.

Always keep approx. 1 cm ash in the bottom of the combustion chamber.

1. A layer of embers will form rapidly if the stove is lit with 2-4 fuel tablets or 7-10 rolled-up sheets of newspaper underneath approx. 1-1.5 kg dry kindling.



2. Open the air supply as much as possible. This is done using the handle above the door.



3. After the paper/solid alcohol tablets have caught fire, leave the fire door ajar about 5-10 cm so that the chimney draws well.



4. When you can see that the chimney is hot enough to draw (after 5-10 minutes), close the door. If all the necessary conditions are met, a thick layer of embers will have been formed in the combustion chamber after another 15-20 minutes.



5. Re-stoking should normally be carried out while embers still remain. Distribute the embers in the bottom, ensuring that most of them are at the front of the stove.



6. Place 2 pieces of wood of approx. 0.7 kg each and approx. 25-30 cm long over the embers in a single layer, with a distance of approx. 1 cm.



7. Open the air supply to maximum and close the door; the fresh wood will then ignite within a couple of minutes.



8. Reduce the amount of combustion air to the desired position, and optimal combustion will continue until there are glowing embers in the bed. During the nominal test, the stoking interval was 60-70 minutes.



9. A new portion of wood can be added by repeating steps 5 & 6.



The stove door should normally be opened gently the first 2-3 cm, then you should wait until the pressure has equalised before opening the door all the way. This technique will prevent smoke from getting out, particularly when there is a poor draught.

The stove door should never be opened when the stove is being fired vigorously.

Once the wood has burned out, it becomes glowing charcoal. If a good layer of embers has already formed on top of a sufficient layer of ash, the stove can keep warm for a very long time, not least due to the favourable qualities of the cast iron.

We would strongly recommend that you do not leave your stove alit at night. It harms the environment and constitutes very poor use of the wood as the gases in the wood do not ignite at the low temperature, but settle as soot (unburned gases) in the chimney and stove. Extreme conditions, such as poor draught in the chimney, large quantities of wood or wet wood, may in the worst-case scenario cause an explosive ignition.

When firing in the summer period, when there is minimal need for heat, the combustion will be poor. The stove provides too much heat so the combustion should be reduced. But always remember to make sure that there are lasting flames until the wood becomes charcoal. If you want a weaker fire, stoke up using less wood.

If you fire the stove using wet wood, a lot of the fuel's thermal energy will be spent forcing the water out of the wood, without releasing any heat to the stove. This incomplete combustion results in a layer of soot being left in the stove, pipe and chimney.

Comparison between firing with wood and oil:

Type of wood (moisture content 20%)	No. of cubic metres per 1000 l oil
Oak	7.0
Beech	7.0
Ash	7.2
Sycamore	7.5
Birch	8.0
Elm	8.9
Common spruce	10.4
Silver fir	10.9

3.0 Routine stove maintenance

3.1 External maintenance

The cast surface of the stove is painted with heat-resistant Senotherm paint. It is best maintained by simply vacuuming it with a soft brush attachment or wiping it down with a dry, dust-free cloth.

If the stove is used too vigorously, the painted surface may assume a greyish tinge over time, but the stove can easily be freshened up with Morsø spray paint, which is available from your local retailer.

Morsø stoves are painted in Morsø charcoal or Morsø light grey. The paint is available either as a spray or in tins.

3.2 Internal maintenance

Glass window

If the stove is used correctly, very little or no soot will be deposited on the ceramic glass window. If soot does form on the glass as the stove is being lit, it will burn away once normal combustion begins in the stove. If the glass window becomes thoroughly covered in soot due to incorrect operation, the soot can be easily removed using a cleaning agent such as Morsø Glass Cleaner. The glass must be cold when you clean it. Avoid stoking the stove with pieces of wood that are so long that they press against the glass window when the door is closed.

Reasons for sooty glass window:

- The fuel is too wet.
- The pieces of fuel are too big/uncut wood.
- The combustion temperature is too low.

Ceramic glass replacement

Ceramic glass cannot be recycled because it has a higher melting point than ordinary glass. If ceramic glass is mixed with ordinary glass, the raw material is spoiled, and the reclaiming process may be halted. Take care that the ovenproof glass does not end up among ordinary recycled waste. That will be a great benefit to the environment.

Note: Should be handed in to a recycling station as ceramic glass.

Internal cast-iron parts and/or wearing parts

The baffles and other components that come in direct contact with the fire and glowing fuel are all wearing parts. As a result, they will be particularly susceptible to burn-through. When used correctly, these parts will last for many years, but overly vigorous use will naturally accelerate the burn-through. Such parts are all easily replaced. If the baffles are damaged and are not replaced in time, the top plate will be exposed to such high temperatures that it may be damaged as well.

Please note that no unauthorised alterations of the design may be undertaken, and that any parts that are replaced must be replaced with original Morsø parts.

Reasons for overly rapid wear of internal parts

- Stove fired too vigorously
- Use of very dry wood (wood from old furniture).
- Too much soot on top of the baffles (please see the section on Cleaning).
- Too much ash in the ash pan (please see the section on Ash).

Gaskets

The gaskets in the doors will wear out over time and should be replaced as required in order to prevent runaway combustion. Use the original Morsø gasket kit.

Note: Normal wearing parts are not covered by Morsø's extended warranty.

A selection of maintenance products (spare parts, glass cleaner, paint, gasket kit, etc.) is available from your Morsø dealer.

3.3 Cleaning the stove

A layer of ash and soot will form as a result of the draught in the chimney and after sweeping, particularly on the top of the upper baffle. This ash will have an insulating effect, which may speed up the burn-through of the baffles.

During normal cleaning, the baffles can be removed from the stove. Once the baffles have been taken out, you can access the flue chamber above the baffles and clean it.

Clean the baffles before reassembling them, and make sure that they are correctly assembled. Nowadays, the chimney sweep must remove the soot in the stove, in addition to sweeping the chimney and cleaning the flue pipe. The number of annual sweepings/cleanings of the stove should be determined in consultation with your chimney sweep.

Ash

As noted above, there should be a layer of approx. 1 cm insulating ash in the bottom of the combustion chamber in order to achieve a high combustion temperature. If the layer of ash is too thick, it can be brushed down into the ash pan.

Empty the ash pan before it gets completely full so that the ash does not insulate around the grate, and thereby speed up the burn-through.

In most cases, the ash will need to be taken away by the waste disposal company. Because embers may be concealed in the ash pan for several days, it may be necessary to store the ash in a container made of non-flammable material before pouring it into a rubbish bag.

Ash from a wood-burning stove will not be of any benefit to your garden as fertiliser. If you have burned colour brochures, or painted or treated wood, etc., in the stove, the resulting ash must not be poured onto soil as it may contain heavy metals.

1. Raise the bottom baffle slightly, and hold it in that position. This loosens the brick panels in the side.



2. Tilt one of the side brick panels and remove it.



3. Tilt one of the side brick panels and remove it.



4. Once the side brick panels have been removed, lower the bottom baffle and lift it out.



5. Lift the upper baffle out of its holder and tilt it out.



6. Make sure that the baffles and brick panels are correctly assembled before lighting the stove after cleaning.



Spare parts for the 6170

Description	Product no.
Inner grate frame	34611000
Upper baffle	79610600
Bottom baffle	79610500
Tertiary box	71610561
Glass window	79610100
Right side brick panel	79610200
Left side brick panel	79610300
Rear brick	79610400

4.0 HETAS amendments

Health and safety precautions

Special care must be taken when installing the stove such that the requirements of the Health and Safety at Work Act are met.

Handling

Adequate facilities must be available for loading, unloading and site handling.

Fire Cement

Some types of fire cement are caustic and should not be allowed to come into contact with the skin. In case of contact wash immediately with plenty of water.

Asbestos

This stove contains no asbestos. If there is a possibility of disturbing any asbestos in the course of installation then please seek specialist guidance and use appropriate protective equipment.

Metal Parts

When installing or servicing this stove care should be taken to avoid the possibility of personal injury.

Note of references to the current UK regulations

In all cases the installation must comply with current Building Regulations, Local Authority Byelaws and other specifications or regulations as they affect the installation of the stove.

It should be noted that the Building Regulations requirements may be met by adopting the relevant recommendations given in British Standards BS 8303, BS EN 15287-1:2007 as an alternative means to achieve an equivalent level of performance to that obtained following the guidance given in Approved Document J.

Please note that it is a legal requirement under England and Wales Building Regulations that the installation of the stove is either carried out under Local Authority Building Control approval or is installed by a Competent Person registered with a Government approved Competent Persons Scheme. HETAS Ltd operate such a Scheme and a listing of their Registered Competent Persons can be found on their website at www.hetas.co.uk.

This stove must not be installed into a chimney that serves any other heating appliance.

More detailed advice about existing chimney usage

NOTE: A chimney height of not less than 4.5 metres measured vertically from the outlet of the stove to the top of the chimney should be satisfactory. Alternatively the calculation procedure given in EN 13384-1 may be used as the basis for deciding whether a particular chimney design will provide sufficient draught.

The outlet from the chimney should be above the roof of the building in accordance with the provisions of Building Regulations Approved Document J.

If installation is into an existing chimney then it must be sound and have no cracks or other faults which might allow fumes into the house. Older properties, especially, may have chimney faults or the cross section may be too large i.e. more than 230 mm x 230 mm. Remedial action should be taken, if required, seeking expert advice, if necessary. If it is found neces

sary to line the chimney then a flue liner suitable for solid fuel must be used in accordance with Building Regulations Approved Document J.

Any existing chimney must be clear of obstruction and have been swept clean immediately before installation of the stove. If the stove is fitted in place of an open fire then the chimney should be swept one month after installation to clear any soot falls which may have occurred due to the difference in combustion between the stove and the open fire.

If there is no existing chimney then any new system must be to the designation described above and in accordance with Building Regulations Approved Document J.

A single wall metal fluepipe is suitable for connecting the stove to the chimney but is not suitable for use as the complete chimney. The chimney and connecting fluepipe must have a minimum diameter of 150 mm and its dimension should be not less than the size of the outlet socket of the stove.

Any bend in the chimney or connecting fluepipe should not exceed 45°. 90° bends should not be used.

Combustible material should not be located where the heat dissipating through the walls of fireplaces or flues could ignite it. Therefore when installing the stove in the presence of combustible materials due account must be taken of the guidance on the separation of combustible material given in Building Regulations Approved Document J and also in these stove instructions.

If it is found that there is excessive draught in the chimney then a draught stabiliser should be fitted. Fitting of a draught stabiliser will affect the requirement for the permanent air supply into the room in which the stove is fitted in accordance with Approved Document J (see also combustion air supply).

Commissioning and handover

Ensure all parts are fitted in accordance with the instructions.

On completion of the installation allow a suitable period of time for any fire cement and mortar to dry out, before lighting the stove. Once the stove is under fire check all seals for soundness and check that the flue is functioning correctly and that all products of combustion are vented safely to atmosphere via the chimney terminal.

On completion of the installation and commissioning ensure that the operating instructions for the stove are left with the customer. Ensure to advise the customer on the correct use of the appliance and warn them to use only the recommended fuel for the stove.

Advise the user what to do should smoke or fumes be emitted from the stove. The customer should be warned to use a fireguard to BS 8423:2002 (Replaces BS 6539) in the presence of children, aged and/or infirm persons.

Warning note on fume emission

Properly installed, operated and maintained this appliance will not emit fumes into the dwelling. Occasional fumes from de-ashing and re-fuelling may occur. However, persistent fume emission is potentially dangerous and must not be tolerated. If fume emission does persist, the following immediate actions should be taken:-

- a) Open doors and windows to ventilate room.
- b) Let the fire out or eject and safely dispose of fuel from the appliance.
- c) Check for flue or chimney blockage, and clean if required.

Do not attempt to relight the fire until the cause of the fume emission has been identified and corrected. If necessary seek expert advice.

Extractor fan

There must not be an extractor fan fitted in the same room as the stove as this can cause the stove to emit smoke and fumes into the room.

Permanent air vent

The stove requires a permanent and adequate air supply in order for it to operate safely and efficiently.

In accordance with current Building Regulations the installer may have fitted a permanent air supply vent into the room in which the stove is installed to provide combustion air. This air vent should not under any circumstances be shut off or sealed.

Chimney cleaning

The chimney should be swept at least twice a year. It is important that the flue connection and chimney are swept prior to lighting up after a prolonged shutdown period.

If the stove is fitted in place of an open fire then the chimney will require sweeping after a month of continuous operation. This is a precaution to ensure that any “softer” deposits left from the open fire usage have not been loosened by the higher flue temperatures generated by the closed stove.

Periods of Prolonged Non-Use

If the stove is to be left unused for a prolonged period of time then it should be given a thorough clean to remove ash and unburned fuel residues. To enable a good flow of air through the appliance to reduce condensation and subsequent damage, leave the air controls fully open.

Use of fireguard

When using the stove in situations where children, aged and/or infirm persons are present a fireguard must be used to prevent accidental contact with the stove. The fireguard should be manufactured in accordance with BS 8423:2002 (Replaces BS 6539).

Use of operating tools

Always use the operating tools provided when handling parts likely to be hot when the stove is in use.

Aerosol sprays

Do not use an aerosol spray on or near the stove when it is alight.